

Arkansas Security Alarm Association



Level I

Student Manual



Arkansas Security Alarm Association

Arkansas Level 1

| | | | | | |
|---------------------------------------|--|---|---|----------------------------------|---------------------------------------|
| <u>00- Introduction</u> | <u>01-Industry Overview</u> | <u>02- Professionalism & Ethics</u> | <u>03-Building Construction</u> | <u>04-Safety</u> | <u>05-Laws, Standards & Codes</u> |
| <u>06-Electricity and Electronics</u> | <u>07-Micro-processors and Computers</u> | <u>08-Tools</u> | <u>09-Prepare for System Installation</u> | <u>10-Wireless</u> | <u>11-Wiring</u> |
| <u>12- Communications</u> | <u>13-Configure – Program</u> | <u>14-Testing & Troubleshooting</u> | <u>15-Train Users</u> | <u>16-As Built Documentation</u> | <u>17- Maintenance & Repairs</u> |

Introduction



Arkansas Security Alarm Association

Arkansas Level 1

WELCOME

to the Arkansas Security Alarm Association's
Level 1

ASAA – Level 1 Course © ASAA 2023Slide 0-1

1



Our Instructor(s)...





ASAA – Level 1 Course © ASAA 2023Slide 0-2

2

Now we want to know a little about you.

- Name
- Company
- Position (Sales, Installations, Tech, etc.)
- City / State
- Years in the industry



ASAA – Level 1 Course © ASAA 2023Slide 0-3

3

Introduction

Goals of this Course

- Compliance with the law
- Bring new industry members up to speed
- Broaden knowledge base
- Brush up on codes & standards



ASAA – Level 1 Course © ASAA 2023 Slide 0-4

4

Course Overview

1. Electronic Systems Industry Overview
2. Professionalism & Ethics
3. Building Construction
4. Safety
5. Law, Standards & Codes
6. General Electricity & Electronics
7. Computers & Networking
8. Tools
9. Prepare For System Installation

ASAA – Level 1 Course © ASAA 2023 Slide 0-5

5

Course Overview

10. Wireless
11. Wiring
12. Communications
13. Configure- Program
14. Test, Troubleshooting, Debug
15. Train Users
16. As Built Documentation
17. Maintenance & Repair Examination

ASAA – Level 1 Course © ASAA 2023 Slide 0-6

6

Introduction

Basic Class Rules..Please:

- No Smoking
- Turn Pagers & Phones to silent or off
- Be prompt! - Mandatory attendance
- Don't Disturb Others - Be Quiet
- Participate

ASAA – Level 1 Course © ASAA 2023 Slide 0-7

7

Why you are here.

- Improve your knowledge
- Enhance your value to your company
- Comply with state requirements

ASAA – Level 1 Course © ASAA 2023 Slide 0-8

8

What ASAA does for you.

- Networking
- Information
- Legislative Efforts
- Training
- Credibility & Exposure



ASAA – Level 1 Course © ASAA 2023 Slide 0-9

9

Introduction

We need your involvement!

- You only get back – what you put in
- This association is your voice to government
- Speak up!

ASAA – Level 1 Course © ASAA 2023 Slide 0-10

10

Disclaimers

- All of the material in this course is copyrighted (2023) by ASAA
- Material may not be recorded, copied or used in any manner without the expressed written permission of the Arkansas Security Alarm Association

ASAA – Level 1 Course © ASAA 2023 Slide 0-11

11

Disclaimers

- Specific manufacturers and products mentioned in this course are intended as examples only and are not to be construed as endorsements
- All codes declare that all manufacturer’s instructions must also be followed to be in compliance

ASAA – Level 1 Course © ASAA 2023 Slide 0-12

12

Introduction



Lets learn together....



ASAA – Level 1 Course © ASAA 2023 Slide 0-13

13

First Impressions Video

Video produced by the Alarm Association of Florida in the early 1980s to show the importance of professionalism.

[Show movie.](#)

ASAA – Level 1 Course © ASAA 2023 Slide 0-14

14

Industry Overview



Arkansas Security Alarm Association

Arkansas Level 1

Electronic Systems Industry Overview

Chapter 1

ASAA – Level 1 Course © ASAA 2023Slide 1-1

1

Industry Terminology

- Every industry has its own set of terms and words.
- Unsure of a term check our Glossary on the ASAA’s web-site at <https://www.aralarm.org>.

ASAA – Level 1 Course © ASAA 2023Slide 1-2

2

Electronic Systems

- Burglar Alarm Systems
- Fire Alarm Systems
- Access Control Systems
- CCTV
- Home Theatre and Home Audio Systems
- Home Control and Automation Systems
- Telephone and Intercom Systems
- Computer Cabling and/or Networks
- Satellite Dish Systems

ASAA – Level 1 Course © ASAA 2023Slide 1-3

3

Industry Overview

Benefits of Electronic Systems

- Security & Life Safety
 - Burglar, Fire & Panic Alarms
- Control
 - Lights, HVAC, etc
- Convenience
 - Automate Coffeemaker, Control Lights,
- Comfort
 - Adjust Heat, AC, etc
- Simplification
 - Program common steps of multiple devices from one control

ASAA – Level 1 Course © ASAA 2023 Slide 1-4

4

Burglar Alarm Systems

- A.K.A- Security Systems and Intrusion Detection Systems
- Consists of sensors, at least one warning device, and a control unit
- Communications capabilities may be included to alert someone off site when the alarm is activated



ASAA – Level 1 Course © ASAA 2023 Slide 1-5

5

Burglar Alarm Objectives

- Detect an intrusion
- Activate a warning device upon detection of an intrusion.
- Deter crime
- Protect life and property
- Bring an appropriate response to an emergency
- Enhance apprehension of Criminals



ASAA – Level 1 Course © ASAA 2023 Slide 1-6

6

Industry Overview

Robbery Alarms

- A.K.A. hold-up, duress, or ambush.
- Activated by inconspicuous devices.
- Silent
- Communications to alert someone off site

ASAA – Level 1 Course © ASAA 2023 Slide 1-7

7

Robbery Alarm Objectives

- Used to notify authorities that a hold-up is in progress



ASAA – Level 1 Course © ASAA 2023 Slide 1-8

8

Cameras

- Closed Circuit Television Systems (CCTV).
- Systems composing:
 - television camera
 - video monitor
 - transmission medium (Cable, fiber or wireless) connecting the two



ASAA – Level 1 Course © ASAA 2023 Slide 1-9

9

Industry Overview

CCTV Camera Objectives

- Monitor the premises.
- Record Activity
- Deter crime
- Alter behavior
- To NOT alter behavior (covert)





ASAA – Level 1 Course © ASAA 2023 Slide 1-10

10

Still Cameras

- Two types
 - Continuous still cameras, also known as automatic cameras, take pictures at preset intervals
 - Sequence cameras take photos only when activated
 - Both types of cameras usually use film cartridges or digital media cards



Older version of a game camera

ASAA – Level 1 Course © ASAA 2023 Slide 1-11

11

Still Camera Objectives

- Designed to take still photographs of an area.

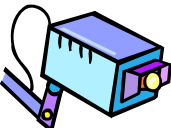

ASAA – Level 1 Course © ASAA 2023 Slide 1-12

12

Industry Overview

Fire Alarm Systems

- Consists of
 - Initiation devices (sensors)
 - Notification Devices (at least one warning device)
 - Control unit and power supplies
 - Communications capabilities may be included to alert someone off site when the alarm is activated

ASAA – Level 1 Course © ASAA 2023 Slide 1-13

13

Fire Alarm Objectives

- Indicate and warn of abnormal conditions
- Provide sufficient warning to allow occupants to escape
- Summon appropriate aid
- Control facilities to control the fire
- Enhance the protection of life
- Reduce property loss and damage



ASAA – Level 1 Course © ASAA 2023 Slide 1-14

14

Access Control

- A system to keep unauthorized personnel from accessing (entering) or egressing (exiting) a certain building, area, office, or other secure point.

Typically composed of a locking mechanism (mag-lock, strike, bolt) and reader (stripe, proximity, biometric) or button.



ASAA – Level 1 Course © ASAA 2023 Slide 1-15

15

Industry Overview

Access Control Objectives

- Allow or deny access/egress based on possession of an certain item or physical trait.
- Track activity through a facility
- Report activity through a facility

*Access control is NOT time and attendance. Consult the Department of Labor before using access control system for time and attendance.

ASAA – Level 1 Course © ASAA 2023 Slide 1-16

16

 **Arkansas Security Alarm Association**
Arkansas Level 1

Section 1-1

Burglar Alarm Systems



ASAA – Level 1 Course © ASAA 2023 Slide 1-17

17

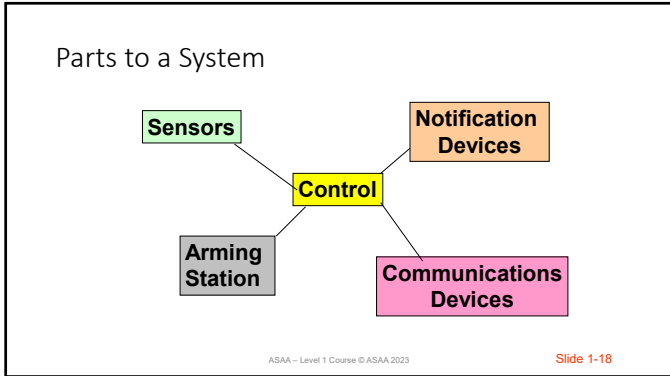

18

Applications of Burglary Sensors

- Point
 - Used to sense around specific objects
- Trap
 - Located in expected traffic area
- Space
 - Sense entire area or room
- Perimeter
 - Sense penetration of outer barrier of area

ASAA – Level 1 Course © ASAA 2023 Slide 1-19

19

Standard Contacts

- Used on doors and windows
- Switch placed on frame
- Magnet placed on door or window
- Separation generates alarm
- Available in surface or flush mount
- Different gaps available
- Built in transmitters



ASAA – Level 1 Course © ASAA 2023 Slide 1-20

20

Balanced Contact

- Used to prevent tampering
- Alarm caused by
 - Separation between switch and magnet
 - Addition of another magnet



ASAA – Level 1 Course © ASAA 2023 Slide 1-21

21

Mechanical Switch

- Used on doors, windows and cabinet doors
- Plunger held in when door or window is closed





ASAA – Level 1 Course © ASAA 2023 Slide 1-22

22

Acoustic Glassbreak Sensor

- Single technology device
- Listen for sound of glass breaking
- Mount on ceiling or wall



ASAA – Level 1 Course © ASAA 2023 Slide 1-23

23

Shock Glassbreak Sensor

- Mounts on glass
- Senses vibration or shock from glass break

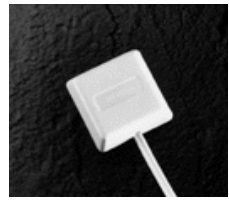

ASAA – Level 1 Course © ASAA 2023 Slide 1-24

24

Industry Overview

Acoustic/Shock Glassbreak Sensor

- Listens for
 - Sound of glass breaking and
 - Shock of glass breaking
- Mount on ceiling or wall



ASAA – Level 1 Course © ASAA 2023 Slide 1-25

25

Screens

- Existing screen or new screen is laced with wire
- One corner of screen has wire to connect to system
- Opposite corner has switch
- Magnet is mounted on frame for switch

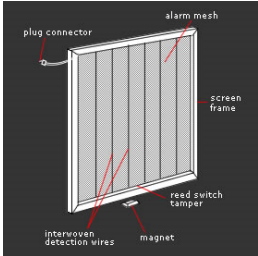

ASAA – Level 1 Course © ASAA 2023 Slide 1-26

26

Passive Infrared (PIR)

- Detect change in radiant heat
- People entering area change pattern
- Mount on wall or ceiling
- Patterns and ranges available
- Available with built in transmitters
- Processing of patterns determines when to indicate alarm



ASAA – Level 1 Course © ASAA 2023 Slide 1-27

27

Industry Overview

Dual-Technology Motion

- PIR combined with Microwave
- Alarm indicated only when both trip



ASAA – Level 1 Course © ASAA 2023 Slide 1-28

28

Audio

- Microphones listen for sounds of break in
- Signal sent when type of noise is heard
- Operator listens to site to decide what is going on

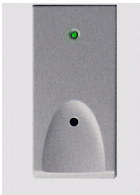

ASAA – Level 1 Course © ASAA 2023 Slide 1-29

29

Outdated Sensors

- Foil
- Traps
- Mats
- Lacing



ASAA – Level 1 Course © ASAA 2023 Slide 1-30

30

Outdated Motion Sensors

- Ultrasonic
- Microwave
- Infrasonic



ASAA – Level 1 Course © ASAA 2023 Slide 1-31

31

 **Arkansas Security Alarm Association**
Arkansas Level 1

Section 1-2

Hold up Alarm Systems



ASAA – Level 1 Course © ASAA 2023 Slide 1-32

32

Holdup or Panic Switches

- Button pressed to indicate an emergency
- Fixed or wireless
- Usually concealed



ASAA – Level 1 Course © ASAA 2023 Slide 1-33

33

Industry Overview

Foot Rail- Kick bar

- Floor mounted
- Activate by foot
- Locks in place till reset



ASAA – Level 1 Course © ASAA 2023 Slide 1-34

34

Money Clip

- Alarm tripped when bill is removed
- Often wire to require two clips to be activated before alarm



ASAA – Level 1 Course © ASAA 2023 Slide 1-35

35



Arkansas Security Alarm Association
Arkansas Level 1

Section 1-3

Fire Alarm Systems



ASAA – Level 1 Course © ASAA 2023 Slide 1-36

36

Manual Pull Stations

- Manually activated device generally used to activate the fire alarm.



Single Action



Double Action

ASAA – Level 1 Course © ASAA 2023 Slide 1-37

37

Fixed Heat Detector

- Triggered when temperature reaches preset limit
- Self restoring or single use
- Variety of temperature settings.



ASAA – Level 1 Course © ASAA 2023 Slide 1-38

38

Rate of Rise Heat Detector

- Triggers when temperature increases at preset rate
- Usually self restores
- Variety of temperature settings.



ASAA – Level 1 Course © ASAA 2023 Slide 1-39

39

Combination Heat Detectors

- Triggers when temperature increases at preset rate or when temperature reaches preset limit
- Usually self restores
- Variety of temperature settings



ASAA – Level 1 Course © ASAA 2023 Slide 1-40

40

Photoelectric Smoke Detector

- Spot Detector
 - Light projected in chamber
 - Smoke reflects light to sensor
- Beam Detector
 - Smoke breaks light beam



Photoelectric



Beam

ASAA – Level 1 Course © ASAA 2023 Slide 1-41

41

Ionization Smoke Detector

- Air in chamber ionized to conduct current
- Smoke disrupts current flow



ASAA – Level 1 Course © ASAA 2023 Slide 1-42

42

CO Detectors

- Detects a toxic colorless and odorless gas



ASAA – Level 1 Course © ASAA 2023 Slide 1-43

43



Arkansas Security Alarm Association
Arkansas Level 1

Section 1-4

Control Panels & Communication

ASAA – Level 1 Course © ASAA 2023 Slide 1-44

44

Touchpads/keypads

- Similar to the keypad on a touch-tone telephone.
- A preset combination number is entered into the keypad to arm (turn on) and disarm (turn off) the system.
- The combination code can be changed.



ASAA – Level 1 Course © ASAA 2023 Slide 1-45

45

Industry Overview

Keyfobs or wearables

Fob: Small radio transmitter, commonly located on a key chain that is used to arm and disarm the alarm system.

Smart watch: a mobile device with a touchscreen display, designed to be worn on the wrist.

May have a panic feature. Smart watch panic may include GPS information.



ASAA – Level 1 Course © ASAA 2023 Slide 1-46

46

Keyswitches

- High security key used to arm (turn on) and disarm (turn off) the system.
- A red light is normally used to indicate if the system is armed.



ASAA – Level 1 Course © ASAA 2023 Slide 1-47

47

Smart Phone Apps

- Control of security system and home control via a smart phone or tablet application.



ASAA – Level 1 Course © ASAA 2023 Slide 1-48

48

Industry Overview

Control Panels

- Controls the system
- Activate annunciators
- Contacts the Monitoring Station
- Powers the system and devices



ASAA – Level 1 Course © ASAA 2023 Slide 1-49

49

Wireless

- Alarm signals from small radio transmitters to a receiver



ASAA – Level 1 Course © ASAA 2023 Slide 1-50

50

Wired Systems

- Uses wires between sensors and the control panel.



ASAA – Level 1 Course © ASAA 2023 Slide 1-51

51

Industry Overview

Zones or Point ID

- Zones- Sensors are divided into groups by
 - Type of signal (Burglar, Fire, Holdup)
 - Type of device (Contact, Motion, etc)
 - Location (East, west, bedroom, living room, etc)
- Point ID- Each Sensor is identified (addressable or polling loop)

ASAA – Level 1 Course © ASAA 2023 Slide 1-52

52

AC Power Source

- Use a dedicated main branch when possible.
- Avoid ground fault interrupted circuits.
- Transformer should be appropriately fastened (according to code) so that it cannot be accidentally unplugged



ASAA – Level 1 Course © ASAA 2023 Slide 1-53

53

Backup Battery

- Include standby power for a minimum of four hours
- Replace every three years or more frequently if a site experiences a high occurrence of power outages or other environmental conditions that drain the life of the battery
- Inspect and test every year
- Battery calculations must be performed on each system to ensure adequate capacity



ASAA – Level 1 Course © ASAA 2023 Slide 1-54

54

Industry Overview

Digital Communicators

- Means to transmit signals to a central station,
- Uses customer's existing phone line.
 - The communicator seizes the customer's phone line and electronically dials the central -station receiver.
 - When the receiver answers, the communicator sends a message in the form of a sequence of tones.
 - A mini -computer in the receiver accepts and acknowledges the message.
 - It then prints out the information for display to the operator.



ASAA – Level 1 Course © ASAA 2023 Slide 1-55

55

Cellular

- The use of stationary cellular telephone equipment to replace or supplement other means of alarm signal communication between the alarm system and the monitoring facility.



ASAA – Level 1 Course © ASAA 2023 Slide 1-56

56

Long Range Radio

- A network of radio transmitters or transceivers capable of sending alarm status messages to one or more radio receivers or transceivers which are at, or in communication with, an alarm monitoring facility or other alarm signal receiving station.



ASAA – Level 1 Course © ASAA 2023 Slide 1-57

57

Industry Overview

Internet

- Uses the Internet to deliver alarm messages.
- Incorporates a very high level of encryption and two-way authentication. Internet transmitters at the alarm site send data to a compatible internet receiver at a central station over the internet.



ASAA – Level 1 Course © ASAA 2023 Slide 1-58

58

Types of Alarm Signals

- **Fire Alarm**
 - A signal that reports a fire, water flowing in a sprinkler system, or dangerous conditions such as smoke or overheated materials that may combust spontaneously
 - **Proper Response-** Call requesting public safety dispatch unless local AHJ allows you to make a call to verify first

ASAA – Level 1 Course © ASAA 2023 Slide 1-59

59

Types of Alarm Signals

- **Holdup Alarm**
 - A silent alarm signal generated by the manual activation of a device intended to signal a robbery in progress
 - **Proper Response-** Call requesting public safety dispatch, then attempt to verify the validity of the signal

ASAA – Level 1 Course © ASAA 2023 Slide 1-60

60

Industry Overview

Types of Alarm Signals

- **Panic Alarm**
 - An audible alarm system signal generated by the manual activation of a device intended to signal a life threatening or emergency situation requiring law enforcement response
 - **Proper Response-** Attempt to reach a responsible party at the alarm site. If that contact fails, call requesting public safety dispatch

ASAA – Level 1 Course © ASAA 2023 Slide 1-61

61

Types of Alarm Signals

- **Ambush or Duress Alarm**
 - A silent signal generated by the entry of a designated code into an arming station in order to signal that the alarm user is being forced to turn off the system and requires law enforcement response
 - **Proper Response-** Call requesting public safety dispatch

ASAA – Level 1 Course © ASAA 2023 Slide 1-62

62

Types of Alarm Signals

- **Burglar Alarm**
 - Usually audible signal indicating a burglary or break in
 - **Proper Response-** Attempt to reach a responsible party at the alarm site. If that contact fails, call a different phone number, usually the cell phone of a responsible party, in an attempt to verify the validity of the alarm signal prior to requesting public safety dispatch (Enhanced Call Verification or ECV)

ASAA – Level 1 Course © ASAA 2023 Slide 1-63

63

Other Types of Signals

- Responsible party should be contacted. Public Safety **should not** be dispatched.
 - Trouble**- A signal indicative of a fault in a monitored circuit or component
 - Supervisory**- A signal indicating the need for action in connection with the supervision of guard tours, the fire suppression systems or equipment, or the maintenance features of related systems

ASAA – Level 1 Course © ASAA 2023 Slide 1-64

64

Other Types of Signals

- Responsible party should be contacted. Public Safety **should not** be dispatched.
 - Late to Close**- Alarm system has not been armed by the agreed upon time deadline
 - Late to Open**- Alarm system has not been disarmed, and there is a time deadline beyond which the user wants to be sure that the premises are occupied
 - Unexpected Openings**- Alarm system has been disarmed at a time outside the normal schedule
 - Closing or Recent Closing**- Signal indicating that the security system has recently been armed.

ASAA – Level 1 Course © ASAA 2023 Slide 1-65

65

Other Types of Signals

- Responsible party should be contacted. Public Safety **should not** be dispatched.
 - Low Battery**- Indicates when battery is almost dead
 - AC Power Fail**- Indicates that primary AC power has failed
 - Industrial Process Alarm**- A signal that reports off normal condition for a wide variety of commercial and industrial processes, including sump-pump operations, water levels, pressures and temperatures, chemical processes, and special furnace operations

ASAA – Level 1 Course © ASAA 2023 Slide 1-66

66

Industry Overview

Other Types of Signals

- Responsible party should be contacted. Public Safety **should not** be dispatched.
 - Reset or Restoral**- Indicates that a device is restored to its original or normal condition
 - Cancel**- Indicates that the previous alarm signal, or alarm in process, is to be disregarded.
 - Test Signal**- Sent in an effort to confirm proper operation of the equipment
 - Late to Test Signal**- Failure to receive an anticipated test signal at the scheduled time.

ASAA – Level 1 Course © ASAA 2023 Slide 1-67

67

Other Types of Signals

- Responsible party should be contacted. Public Safety **should not** be dispatched.
 - Exit Error**- A signal produced when an entry/exit zone is still violated at the expiration of the Exit Time
 - Test Initiation Report**- At the initiation of a test, the control panel sends a message to the central station that a test is in progress
 - Test Termination Report**- When a test is terminated, the control panel sends a message to the central station that the test is over

ASAA – Level 1 Course © ASAA 2023 Slide 1-68

68

Monitoring Station

- Location to
 - Monitor signals
 - Analyze signals
 - Verify signals
 - Record activity
 - Request response
 - Follow-up



ASAA – Level 1 Course © ASAA 2023 Slide 1-69

69

Industry Overview

Response

- Customer
- Alarm Company
- Guards
- Police-Sheriff
- Fire Department
- Ambulance



ASAA – Level 1 Course © ASAA 2023 Slide 1-70

70



Arkansas Security Alarm Association
Arkansas Level 1

Section 1-5

Notification Devices

ASAA – Level 1 Course © ASAA 2023 Slide 1-71

71

Horns

- Noise -making device used to indicate an alarm or other event.
- Available in 12 or 24 volt models



ASAA – Level 1 Course © ASAA 2023 Slide 1-72

72

Strobes

- A visual indicator light with very rapid, bright flashes.
- Used to indicate an alarm or other event.
- Lens colors may vary.



ASAA – Level 1 Course © ASAA 2023 Slide 1-73

73

Active Graphic Annunciator

- Board or CRT screen with graphics to delineate alarm or sensor locations.
- A visual indicator showing the location of an alarm.
- Annunciators pinpoint the exact location of an alarm or problem.
- With their help, the alarm user can locate a faulted door or sensor at closing time.
- In addition, service personnel can quickly locate a system defect.



ASAA – Level 1 Course © ASAA 2023 Slide 1-74

74

Static Graphic Annunciator

- LEDs illuminate areas of a map of the facility to show the location of an alarm or event.
- Annunciators pinpoint the exact location of an alarm or problem.
- With their help, the alarm subscriber can locate a faulted door or sensor at closing time. In addition, service personnel can quickly locate a system defect.



ASAA – Level 1 Course © ASAA 2023 Slide 1-75

75

Tabular Annunciator

- LEDs illuminate a labeled area of a grid to show the location of an alarm.
- Annunciators pinpoint the exact location of an alarm or problem.
- With their help, the alarm subscriber can locate a faulted door or sensor at closing time.
- In addition, service personnel can quickly locate a system defect.





ASAA – Level 1 Course © ASAA 2023 Slide 1-76

76

Siren

- An electronic device that produces a very loud, hard to ignore sound when activated.
- Flush or surface mount.
- Self contained or a combination of speaker and siren driver.
- Continuous tone or multi-tone.



ASAA – Level 1 Course © ASAA 2023 Slide 1-77

77

Bell

- Electromechanical noise-making device.
- A clapper is moved electromechanically to strike the bell and produce a loud ringing sound.



ASAA – Level 1 Course © ASAA 2023 Slide 1-78

78

Smoke Emitting Devices

- When activated, a smoke emitting device rapidly produces a dense smoke, fog or vapor that reduces the visibility in a room to a minimum.
- Smoke Emitting Devices are intended to be integrated into the premises alarm system, but may be a self-contained stand-alone unit.
- They should be manufactured specifically for this use and not adapted from other uses, such as entertainment.
- Some models allow user programming, such as delays, resets and control of volume of emission



ASAA – Level 1 Course © ASAA 2023 Slide 1-79

79



Arkansas Security Alarm Association
Arkansas Level 1

Section 1-6

Camera Systems (CCTV)

ASAA – Level 1 Course © ASAA 2023 Slide 1-80

80

Camera Types

- Black and white
- Color
- Dome
- Pan / Tilt / Zoom
- Bullet
- Vandal Proof
- High Definition (mega-pixel) or NTSC



ASAA – Level 1 Course © ASAA 2023 Slide 1-81

81

Industry Overview

Transmission Methods

Connecting the cameras to the recorder

- Coax (RG59U, RG6U, or RJ11U)
- IP based (Cat5e or Cat6)
- Baluns (video over UTP – unshielded twisted pair)
- Fiber Optics
- Wireless



ASAA – Level 1 Course © ASAA 2023 Slide 1-82

82

Recorders

- Video Cassette Recorder (VCR)
- Digital Video Recorder (DVR)
 - PC Based (Windows operating system)
 - Imbedded (typically Linux)
- Network Video Recorder



ASAA – Level 1 Course © ASAA 2023 Slide 1-83

83



Arkansas Security Alarm Association
Arkansas Level 1

Section 1-7

Access Control Systems

ASAA – Level 1 Course © ASAA 2023 Slide 1-84

84

Industry Overview

Access Control Systems

- Not regulated in Arkansas (do not need a license to install)
- Any time access control systems are installed, you must consult NFPA 72 for fire code restrictions.





NFPA 72-21.9

ASAA – Level 1 Course © ASAA 2023 Slide 1-85

85

Access Control Readers

- Reads and decodes information to be processed by the access control system.





Proximity | Fingerprint | Palm Geometry | Retina Scan | Keypad

ASAA – Level 1 Course © ASAA 2023 Slide 1-86

86

Exit (Egress) Control Devices

- Readers (for anti-pass back or traffic flow control)
- Buttons
- Motions and mats
- Door hardware



- See Arkansas Fire Prevention Code 2021, Chapter 10

ASAA – Level 1 Course © ASAA 2023 Slide 1-87

87

Locking Mechanism

- Mag-lock
- Door Strike
- Electric Locks



ASAA – Level 1 Course © ASAA 2023

Slide 1-88

88



Arkansas Security Alarm Association
Arkansas Level 1

Section 1-8

Other Systems

ASAA – Level 1 Course © ASAA 2023

Slide 1-89

89

System Integration

- Alarm system may interact with
 - Cameras
 - Access Control or door locks
 - Home Automation
 - Energy Management
 - Light control



ASAA – Level 1 Course © ASAA 2023

Slide 1-90

90

Professionalism & Ethics



Arkansas Security Alarm Association

Arkansas Level 1

Professionalism & Ethics

Chapter 2

ASAA – Level 1 Course © ASAA 2023Slide 2-1

1

Definitions

- **Professionalism** - the standing, practice, or methods of a professional, as distinguished from an amateur.

- **Ethics** - that branch of philosophy dealing with values relating to human conduct, with respect to the rightness and wrongness of certain actions and to the goodness and badness of the motives and ends of such actions.

ASAA – Level 1 Course © ASAA 2023Slide 2-2

2

Company Standards

- **Common sources**
 - Employee handbook
 - Company policy
 - On the Job Training
- **Common Reasons to Set Standards**
 - Meet Customer Expectations
 - Makes Troubleshooting easier
 - It is more efficient



ASAA – Level 1 Course © ASAA 2023Slide 2-3

3

Professionalism & Ethics

Company Obligations to Customer

- Meet customer need
- Comply with law
- Install full system as sold
- Test
- Ensure user understanding
- Offer ongoing service and repair



ASAA - Level 1 Course © ASAA 2023 Slide 2-4

4

Employee Obligations To Employer

- Do your best!
- Promote customer satisfaction
- Promote company growth
- Work as a PROFESSIONAL !!



ASAA - Level 1 Course © ASAA 2023 Slide 2-5

5

Employee Obligations to Customer

- You only get one chance to make a first impression for YOU and YOUR COMPANY
- Look the part - dress to the level of professional that you want to be seen as
- Be Prepared - have everything you need ready to go



ASAA - Level 1 Course © ASAA 2023 Slide 2-6

6

Professionalism & Ethics

Courtesy

- Good customer service attracts & retains customers
- Treat the customer with respect - they are signing your check for that day !



ASAA - Level 1 Course © ASAA 2023 Slide 2-7

7

Sales Ethics:

- Educate yourself
- Listen to your customer's needs & desires
- Design to meet the customer's need
- Inform your customer of ALL contract details
- Do not mislead a customer
- Remember - One Size Does **Not** Fit All

ASAA - Level 1 Course © ASAA 2023 Slide 2-8

8

Installer Ethics:

- Educate yourself
- Be honest about system operation
- Comply with laws and standards
- Be safe
- Work as if it is your own home or business
- Make sure that the customer is comfortable with system operation after completion
- Make sure you leave each home or business cleaner than you found it

ASAA - Level 1 Course © ASAA 2023 Slide 2-9

9

Professionalism & Ethics

General Obligations:

- Work WITH your local Police and Fire departments
- Promote the industry's integrity through your local and state associations
- Work within your local community and local association to promote ethics and integrity in our industry

ASAA - Level 1 Course © ASAA 2023 Slide 2-10

10

Customer Communications

- Read the job documentation
- Explain what you will be installing
- Verify job specifications with customer
- Document changes

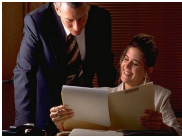

ASAA - Level 1 Course © ASAA 2023 Slide 2-11

11

Impact of False Alarms

- Can lead to fines and suspension of public safety response
- Can endanger responders
- Reduces effectiveness of system
- Adds to cost of system



ASAA - Level 1 Course © ASAA 2023 Slide 2-12

12

Professionalism & Ethics

False Alarm Definitions

An alarm call is considered to be false if a request for immediate assistance of emergency personnel is made and:

- An actual emergency situation or threatened criminal activity does not or did not exist.
- Is a result of accidentally or negligently activated signals, as well as any signal that is the result of faulty, malfunctioning, or improperly installed or maintained equipment.
- Is a result of an act of God (i.e. weather conditions).
- Emergency personnel are dispatched and the call is canceled while the responding personnel are en route.
- The responding emergency personnel determines that the request was otherwise unwarranted.

- City of Little Rock

ASAA – Level 1 Course © ASAA 2023 Slide 2-13

13

False Alarm Definitions

False Alarm: Notification of an alarm condition when no evidence of the event that the alarm signal was designed to report is found.

- NFPA 731 3.3.12 (2023)

ASAA – Level 1 Course © ASAA 2023 Slide 2-14

14

Percentage vs. Factor

| | |
|---|---|
| <p style="text-align: center; color: red;">False Alarm Percentage</p> <p style="color: red;">Number of alarms where no burglar was caught divided by total number of calls for service.</p> <p style="color: red;">“98% of alarms in the City of Little Rock are false alarms.”</p> | <p style="text-align: center; color: green;">False Alarm Factor</p> <p style="color: green;">Number of false dispatches divided by the number of systems installed.</p> <p style="color: green;">“Montgomery County, Maryland has a false alarm factor of .9”</p> |
|---|---|

ASAA – Level 1 Course © ASAA 2023 Slide 2-15

15

Professionalism & Ethics

Percentage Based Results

| Prior to False Alarm Reduction Steps | After False Alarm Reduction Steps |
|--------------------------------------|-----------------------------------|
| 10,000 systems installed | 10,000 systems installed |
| 30,000 alarms in year | 5,000 alarms in year |
| 50 bad guys caught | 50 bad guys caught |
| 29,950 false alarms | 4,950 false alarms |
| 99.83% false alarm rate | 99.0% false alarm rate |

ASAA - Level 1 Course © ASAA 2023 Slide 2-16

16

Factor Based Results

| Prior to False Alarm Reduction Steps | After False Alarm Reduction Steps |
|--|---|
| 10,000 systems installed | 10,000 systems installed |
| 30,000 alarms in year | 5,000 alarms in year |
| 50 bad guys caught | 50 bad guys caught |
| 29,950 false alarms | 4,950 false alarms |
| False Alarm Factor is 2.995 alarms per system | False Alarm Factor is .495 alarms per system (One false alarm every two years) |

ASAA - Level 1 Course © ASAA 2023 Slide 2-17

17

False Alarm Prevention

- Proper Design
- Quality Equipment
- Proper Installation
- Proper User Education
- Verify Before Dispatch
- Follow-up on Each False Alarm

IT IS EVERYONE'S RESPONSIBILITY TO



FALSE ALARMS

ASAA - Level 1 Course © ASAA 2023 Slide 2-18

18

Professionalism & Ethics

Free Video from NESA

- The National Electronic Security Alliance has created a video, free for download, to help our customers understand the impact of false alarms.

Download at: <http://www.nesaus.org>

[Play video](#)
[Law enforcement video](#) (SIAC video describes options to law enforcement, including: fines, broadcast and file, fining alarm companies, and no response.

ASAA – Level 1 Course © ASAA 2023 Slide 2-19

19

Do Your Best!

- Earn reputation as a professional
- Expand your opportunities
- Increase your value
- Gain satisfaction

ASAA – Level 1 Course © ASAA 2023 Slide 2-20

20

Building Construction



Arkansas Security Alarm Association
Arkansas Level 1

Building Construction

Chapter 3

ASAA – Level 1 Course © ASAA 2023Slide 3-1

1

Construction Materials and Methods

- Wood or metal framing
- Brick, paneling, plaster or drywall
- Paint or wallpaper
- Drop ceiling, attic
- Crawl space, open or finished basement

ASAA – Level 1 Course © ASAA 2023Slide 3-2

2

Construction Drawings

- **Structural Drawings**
 - Engineering of building
- **Electrical Drawings**
 - Power, lighting, alarm and communications
- **Mechanical Drawings**
 - Plumbing, heating, air conditioning

ASAA – Level 1 Course © ASAA 2023Slide 3-3

3

Building Construction









Construction Documents

- **Specifications**
 - Detail description of job requirements
- **Diagrams**
 - Detailed drawings of specific projects
- **Schedules**
 - Lists of materials to be used on the job
- **Shop Drawings**
 - Detailed drawings of how a device or component will be installed

ASAA – Level 1 Course © ASAA 2023 Slide 3-4

4

Home Styles

| | | | |
|---|---|--|--|
|  Cape Cod |  Colonial |  Contemporary |  Craftsman |
|  European |  Southern |  Ranch |  Victorian |

ASAA – Level 1 Course © ASAA 2023 Slide 3-5

5

Types of Doors

| | | |
|--|---|---|
|  Steel Entry Doors |  Patio or Sliding Doors |  French Doors |
|  Wood, fiberglass or composite Entry Doors |  Overhead or Garage Doors |  Pet Doors |

ASAA – Level 1 Course © ASAA 2023 Slide 3-6

6

Building Construction

Types of Windows

ASAA – Level 1 Course © ASAA 2023 Slide 3-7

7

Common Insulation Methods

ASAA – Level 1 Course © ASAA 2023 Slide 3-8

8





Proper Fasteners

ASAA – Level 1 Course © ASAA 2023 Slide 3-9

9

Building Construction





Solid Material Anchors

| | | | |
|---------------------------|---|--------------------------|---|
| Plastic Expansion Anchors |  | Leadwood Screw Anchor |  |
| Ribbed Expansion Anchors |  | Concrete Drop-In Anchors |  |

ASAA – Level 1 Course © ASAA 2023 Slide 3-10

10

Hollow Wall Anchors

| | | | |
|--------------------------------|---|--------------------------|---|
| Winged Plastic Anchors |  | Threaded Drywall Anchors |  |
| Molly Bolts aka Sleeve Anchors |  | Threaded Drywall Toggles |  |
| | | Toggle Bolts |  |

ASAA – Level 1 Course © ASAA 2023 Slide 3-11

11

Plenum Spaces

Space used for Air Return

- Between Structural Ceiling and Drop Ceiling
- Between Structural Floor and Raised Floor

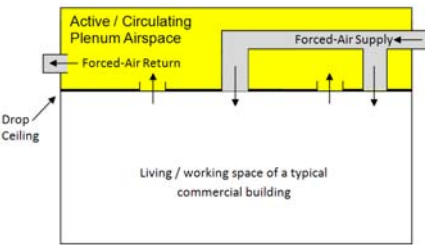

ASAA – Level 1 Course © ASAA 2023 Slide 3-12

12

Safety



Arkansas Security Alarm Association

Arkansas Level 1

Safety

Chapter 4

ASAA – Level 1 Course © ASAA 2023Slide 4-1

1

OSHA

- OSHA enforces safety standards

- Visit www.osha.gov for more information
- Standards 1926 & 1910 apply to our industry

ASAA – Level 1 Course © ASAA 2023Slide 4-2

2

OSHA Standards

| | |
|-----|---|
| 423 | Electrical Wiring Methods, Components & Equipment General Use |
| 220 | Electrical, General Requirements |
| 174 | Electrical, Wiring Design & Protection |
| 118 | Fall Protection |
| 96 | Manually Propelled Mobile Ladder Stands & Scaffolds |

ASAA – Level 1 Course © ASAA 2023Slide 4-3

3

Safety

Job Site, Tools, Open Areas, Construction Rules, etc.

- Keep control of your tools
- Block off unsafe areas
- Clean up unsafe debris



ASAA – Level 1 Course © ASAA 2023 Slide 4-4

4

Install Cable Safely



- Do not overreach on ladders
- Do not rest on drop ceiling supports
- Know what is on the other end of conduits before you fish
- Remove power before you disconnect or connect circuits

ASAA – Level 1 Course © ASAA 2023 Slide 4-5

5

Hazardous Environments

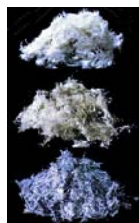
- Asbestos
- Crawl Space
- Gas in manholes and confined spaces



ASAA – Level 1 Course © ASAA 2023 Slide 4-6

6

Most Common Causes of Accidents

- Failure to communicate
 - Coordinate with fellow workers and others on each job
- Poor work habits
 - Pay attention, avoid horseplay, do not rush
- Drug or alcohol use
- Lack of skill
 - Unsure how it works – Ask for help



ASAA – Level 1 Course © ASAA 2023 Slide 4-7

7

Use Personal Safety Devices



ASAA – Level 1 Course © ASAA 2023 Slide 4-8

8

Clothing, Hair & Jewelry

- Wear proper clothing
- Keep long hair, ID badges and jewelry out of the path of drills
- Use care with metal watches, rings and jewelry around electricity

ASAA – Level 1 Course © ASAA 2023 Slide 4-9

9

Driver, Vehicle, etc

- Pay attention
- Focus on driving not cell phone, radio, lunch, map, etc
- Wear seatbelt
- Obey traffic laws
- Keep vehicle maintained
- Drive Defensively



ASAA – Level 1 Course © ASAA 2023 Slide 4-10

10

Ladder Setup

- Place ladder on a clean, slip free, level surface
- Extend the ladder 3-4 feet above the top support, if used to access roof or other elevated surface
- Anchor or secure the top of the ladder when the 3-4 foot extension is not possible
- Place the ladder base $\frac{1}{4}$ of the height of the ladder from the wall when using a straight ladder

ASAA – Level 1 Course © ASAA 2023 Slide 4-11

11

Safe Ladder Use

- Check shoes and rungs for slippery surfaces
- Never allow more than one person on a ladder
- Use tool belts or hand lines to carry objects
- Do not allow others to work under a ladder in use

ASAA – Level 1 Course © ASAA 2023 Slide 4-12

12

Ladder Safety

- Select the right ladder for the job. Use only Class II & III fiberglass ladders around electricity
- Inspect ladder before use
- Face ladder and Always hold on with one hand
- Never reach too far to either side or rear to maintain balance



ASAA – Level 1 Course © ASAA 2023 Slide 4-13

13

Safe Ladder Use

- Never climb higher than second step from top on a stepladder or third from the top on a straight ladder
- Never attempt to move, shift, or extend ladder while in use
- If you have a fear of heights – don't climb a ladder

ASAA – Level 1 Course © ASAA 2023 Slide 4-14

14

Electrical



- Render equipment or circuits inoperative while work is performed
- Attach tags at all points where such equipment or circuits can be energized
- Place tags to identify plainly the equipment or circuits being worked on

ASAA – Level 1 Course © ASAA 2023 Slide 4-15

15

Disconnect the Power First!!!

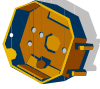
- Turn off the breakers on any equipment you are working on
- Don't work on high voltage circuits
- Cover open circuit panel boxes.
- Verify conduits prior to running metallic fish tapes



ASAA – Level 1 Course © ASAA 2023 Slide 4-16

16

250mA = Cardiac Arrest

- 1/4th of an Ampere with sufficient voltage to push it through you is deadly
- 120VAC is plenty sufficient!



ASAA – Level 1 Course © ASAA 2023 Slide 4-17

17

Grounding

- NEC Article 250 describes proper grounding techniques.
- Minimum 14AWG to panel.
- Minimum 6AWG to grid (bonding)
- Should be the first wire connected in the panel
- Transients, spikes and surges have no place to go if there is no ground wire

ASAA – Level 1 Course © ASAA 2023 Slide 4-18

18

High Voltage :>30Volts

- NEC describes high voltage as being over 30 volts
- Anything over this requires an electrician's license
- Exception is communications circuits

ASAA – Level 1 Course © ASAA 2023 Slide 4-19

19

CPR- Cardiopulmonary Resuscitation

- Take a CPR Class
- Make sure the scene is safe for you to help
- Make sure you have universal precautions: gloves, pocket mask, etc
- Make sure you know how many patients you have
- Determine if they are conscious by tapping and shouting "Are you OK?"
- If no response have someone call 911

ASAA – Level 1 Course © ASAA 2023 Slide 4-20

20

GFCI

The U.S. Consumer Product Safety Commission (CPSC) recommends the use of a ground-fault circuit-interrupter (GFCI) with every power tool to protect against electrical shock hazards

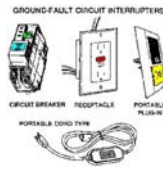

ASAA – Level 1 Course © ASAA 2023 Slide 4-21

21

Electric Shock

1. Remove the victim from the source of electricity before you touch him
2. If he is not breathing, begin rescue breathing immediately; a victim whose heart has stopped breathing needs CPR
3. If the person is unconscious, but is breathing and has a heartbeat, you should place him in the recovery position and monitor his breathing and heart rate until medical help arrives

ASAA – Level 1 Course © ASAA 2023 Slide 4-22

22

Heat

1. Cool the body of a heatstroke victim immediately
2. If possible, put him in cool water; wrap him in cool wet clothes; or sponge his skin with cool water, rubbing alcohol, ice, or cold packs
3. Once the victim's temperature drops to about 101 F, you may lay him in the recovery position in a cool room

ASAA – Level 1 Course © ASAA 2023 Slide 4-23

23

Heat

4. If his temperature begins to rise again, you will need to repeat the cooling process
5. If he is able to drink, you may give him some water
6. DO NOT GIVE A HEATSTROKE VICTIM ANY KIND OF MEDICATION
7. You should watch for signs of shock while waiting for medical attention

ASAA – Level 1 Course © ASAA 2023 Slide 4-24

24

Safety

Report All Accidents

- Report all injuries and accidents to your supervisor
- If you do not you may not be properly covered by insurance if a minor injury proves to be serious later

ASAA – Level 1 Course © ASAA 2023 Slide 4-25

25

Bad Idea #1



ASAA – Level 1 Course © ASAA 2023 Slide 4-26

26

Bad Idea #2



ASAA – Level 1 Course © ASAA 2023 Slide 4-27

27

Safety

Bad Idea #3



ASAA – Level 1 Course © ASAA 2023 Slide 4-28

28

Bad Idea #4



ASAA – Level 1 Course © ASAA 2023 Slide 4-29

29

Bad Idea #5



ASAA – Level 1 Course © ASAA 2023 Slide 4-30

30

Safety

Bad Idea #6



ASAA – Level 1 Course © ASAA 2023

Slide 4-31

31

Bad Idea #7



ASAA – Level 1 Course © ASAA 2023

Slide 4-32

32

Bad Idea #8



ASAA – Level 1 Course © ASAA 2023

Slide 4-33

33

Law, Standards & Codes



Arkansas Security Alarm Association

Arkansas Level 1

Law, Standards and Codes

Chapter 5

ASAA – Level 1 Course © ASAA 2023Slide 5-1

1

What is a Code?

- Codes tell us when a given type system is required
- Codes are easily and often incorporated into laws
- Codes usually incorporate standards into law

ASAA – Level 1 Course © ASAA 2023Slide 5-2

2

State Adopted Code

Arkansas Fire Prevention Code
2021 edition

Based on the 2021 International Building Code (IBC), International Fire Code (IFC), the International Residential Code (IRC), and International Existing Building Code.



ASAA – Level 1 Course © ASAA 2023Slide 5-3

3

What is a Standard?

- A set of specifications or rules
- Level of quality
- Type of equipment
- Type of training
- How the system should operate

ASAA – Level 1 Course © ASAA 2023 Slide 5-4

4

State Referenced Standards
Relating to Fire Alarm Systems

2019 NFPA 72 –
National Fire Alarm
Code Book



2020 NFPA 70 –
National Electrical
Code

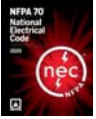

ASAA – Level 1 Course © ASAA 2023 Slide 5-5

5

Following Codes & Standards:

- Results in fewer false alarms
- Lower maintenance costs
- Better system performance
- More credibility!

ASAA – Level 1 Course © ASAA 2023 Slide 5-6

6

Law, Standards & Codes

Liability

- Substandard work leads to faulty systems
- Faulty systems lead to losses or injuries for customers
- Legal action can result affecting the industry, company and employee
- Potential for loss of license for company or employee for code / law violations
- Potential monetary damages or fines

ASAA – Level 1 Course © ASAA 2023 Slide 5-7

7

Judge and Jury

- Courts take into consideration whether any recognized standard was followed
- The excuse: “Everyone is doing it this way” will not win a court case!

ASAA – Level 1 Course © ASAA 2023 Slide 5-8

8

Where Do Standards Come From Anyway?

- Experts in the field
- Interested public
- Events (crimes, fires)
- Industry (manufacturers, insurance, owners)
- Agencies (fire, police, EMS)

ASAA – Level 1 Course © ASAA 2023 Slide 5-9

9

Standards are updated periodically

- Most standards get updated every three years.
(Arkansas has adopted all those on the top row)



ASAA – Level 1 Course © ASAA 2023

Slide 5-10

10

Types Of Standards

- International Standards
- National Standards
- State Standards
- Local Standards
- Company Standards
- Manufacturers Instructions

ASAA – Level 1 Course © ASAA 2023

Slide 5-11

11

Which Codes And Standards Do I Use?

- Look to your local AHJ
(Authority Having Jurisdiction)
- If your AHJ doesn't specify, NFPA is a safe bet
- Always follow NFPA 70 (National Electric Code)
for all types of systems

ASAA – Level 1 Course © ASAA 2023

Slide 5-12

12

Law, Standards & Codes

Which Codes And Standards Do I Use?

- Many of the cities and towns adopt their own set of codes and standards.
- Arkansas Security Alarm Association has compiled a list on our web-site.



ASAA – Level 1 Course © ASAA 2023

Slide 5-13

13

Who is the AHJ anyway?

- “The organization, office or individual responsible for approving equipment, installation or procedure” - *NFPA*
 - Fire Department: Chief, Fire Marshal
 - Department of Labor
 - Health Department
 - Insurers
 - Owners

ASAA – Level 1 Course © ASAA 2023

Slide 5-14

14

The AHJ can approve & accept products & procedures.

- “**Approved**” indicates they will certify and support those products, applications or procedures
- “**Listed**” means that a product has met certain qualifications and testing criteria - U.L./F.M
- “**Accepted**” means that the AHJ considers it “adequate or equivalent” to satisfy a requirement or standard

ASAA – Level 1 Course © ASAA 2023

Slide 5-15

15

Law, Standards & Codes

Shall & Should...

- **“Shall”** means it is mandatory. You will do it this way
- **“Should”** means its recommended but not required. Be ready to explain to the judge and jury why you didn’t

ASAA – Level 1 Course © ASAA 2023 Slide 5-16

16

What is this NFPA?

The National Fire Protection Association (NFPA), is an international, nonprofit, membership organization to protect people, their property and the environment from destructive fire



For more info visit www.NFPA.org

May view codes/standards for free.

ASAA – Level 1 Course © ASAA 2023 Slide 5-17

17

Other Standards

- UL- Underwriters Laboratories
(testing laboratory that also writes burglary standards)
- SIA- Security Industry Association
(manufacturer’s association that writes false alarm reduction standards)
- NFPA 731 – Standard for the Installation of Electronic Premises Security Systems



ASAA – Level 1 Course © ASAA 2023 Slide 5-18

18

Private Investigators and Private Security Agencies Act



501-618-8600

ASAA – Level 1 Course © ASAA 2023

Slide 5-19

19

Company License Classes

- **Class E - Restricted:** Burglar Alarms, Cameras, Fire Alarm Systems in occupancies NOT required by the Arkansas Fire Prevention Code (may NOT install alarm systems in residences)
- **Class E - Unrestricted:** Burglar Alarms, Cameras, Fire Alarm Systems. No restrictions on occupancy classes or square footage of buildings.
- **Class E-M:** Monitoring only
- **Class E-S:** Single Station Fire in One or two family dwellings

ASAA – Level 1 Course © ASAA 2023

Slide 5-20

20

Who Is Covered?

- Licenses:
- Alarm Systems Company

- Registrations
- Alarm Systems Agent
 - Alarm Systems Monitor
 - Alarm Systems Technician
 - Alarm Systems Apprentice

ASAA – Level 1 Course © ASAA 2023

Slide 5-21

21

Alarm Systems Company

Any person, firm, association, or corporation that for a fee or other valuable consideration installs, services, sells on site, performs a survey of the premises to be protected, monitors, or responds to electrical, electronic, or mechanical alarm signal devices, burglar alarms, television cameras, or still cameras used to manually or automatically signal or detect burglary, fire, breaking or entering, shoplifting, pilferage, theft, hold-up, or other illegal or unauthorized activity

ASAA – Level 1 Course © ASAA 2023 Slide 5-22

22

Alarm Systems Agent

Any individual employed by an alarm systems company who sells on site, performs a survey of the premises to be protected, or responds to alarm signal devices, burglar alarms, or cameras



ASAA – Level 1 Course © ASAA 2023 Slide 5-23

23

Alarm Systems Monitor

Any individual employed by an alarm systems company who monitors or responds



ASAA – Level 1 Course © ASAA 2023 Slide 5-24

24

Alarm Systems Technician

Any individual employed by an alarm systems company who installs, services, or repairs on site



ASAA – Level 1 Course © ASAA 2023 Slide 5-25

25

Alarm Systems Apprentice

Any individual employed by an alarm systems company who installs, services, or repairs on site that is supervised by an alarm systems technician, a supervisor of technicians, or a manager



ASAA – Level 1 Course © ASAA 2023 Slide 5-26

26

ID Card

- Upon Termination
 - return ID card to employer within five (5)
 - notify the Arkansas State Police in writing and pay a transfer fee prior to becoming employed with a different agency
 - employer must return card to Arkansas State Police within seven (7) days



ASAA – Level 1 Course © ASAA 2023 Slide 5-27

27

Unlawful Acts

- No licensee, or officer, director, partner, manager, or employee of a licensee, except full-time police officers, shall use a title, wear a uniform, use an insignia, use an identification, or make any statement with the intent to give the impression that he or she is connected in any way with the federal government, a state government, county government, city government, or any political subdivision of a state government.

ASAA – Level 1 Course © ASAA 2023 Slide 5-28

28

Unlawful Acts

- It is unlawful and punishable as provided in § [17-40-104](#) for any person to represent falsely that he or she is employed by a licensee.

ASAA – Level 1 Course © ASAA 2023 Slide 5-29

29

Possible Disciplinary Actions

- Arkansas State Police may revoke, suspend, reprimand, deny registration, license or renewal or fine up to \$1000 for each violation

ASAA – Level 1 Course © ASAA 2023 Slide 5-30

30

Grounds for Disciplinary Action

- Made a material misstatement in the application for or renewal of a license, registration, or security officer commission
- Violation of this act or any rule
- Conviction of a felony, a Class A misdemeanor, a crime involving an act of violence, or a crime involving moral turpitude
- Practiced fraud, deceit, or misrepresentation;
- Demonstrated incompetence or untrustworthiness in his or her actions.

ASAA – Level 1 Course © ASAA 2023 Slide 5-31

31

Penalties

- Any person who violates any provision of this chapter is guilty of a Class A misdemeanor. Any person who violates any provision of this chapter within one (1) year of a previous violation is guilty of a Class D felony.

ASAA – Level 1 Course © ASAA 2023 Slide 5-32

32

Minimum Standards

Codes and standards contain the minimum requirements

We can exceed these minimums

ASAA – Level 1 Course © ASAA 2023 Slide 5-33

33



Arkansas Security Alarm Association

Arkansas Level 1

Electricity & Electronics

Chapter 6

ASAA – Level 1 Course © ASAA 2023Slide 6-1

1

Types of Electricity

- **Static**
 - Lightning, Friction
- **Alternating Current (AC)**
 - Power Company - Generators
- **Direct Current (DC)**
 - Batteries, Rectified AC

ASAA – Level 1 Course © ASAA 2023Slide 6-2

2

Alternating Current “A.C.”

- Current moves in both directions over the same conductor
- Changes directions 60 times per second (60 cycles or hertz)
- Generated by mechanically moving conductors through North then South magnetic fields
- Can be rectified to direct current (D.C.)

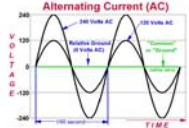

The graph shows a sine wave representing AC voltage over time. The y-axis is labeled 'VOLTAGE' and ranges from -240 to 240. The x-axis is labeled 'TIME'. The peak of the wave is labeled '240 Volts AC' and the trough is labeled '-240 Volts AC'. A horizontal line at the 120 level is labeled '120 Volts AC'. A note indicates that the 'Rectified DC' is 60 Volts DC.

ASAA – Level 1 Course © ASAA 2023Slide 6-3

3

General Electricity & Electronics

Direct Current "D.C."

- Current moves in only one direction
- Generated from a chemical reaction
- Comes from a battery or rectified A.C.



ASAA – Level 1 Course © ASAA 2023

4

Parts to a Circuit

- **Power Source**
 - Wall socket, generator, battery
- **Conductors**
 - Wire
- **Load**
 - Devices

ASAA – Level 1 Course © ASAA 2023

Slide 6-5

5

Circuits

When a circuit is closed - current will flow

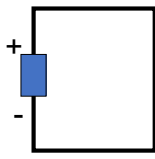

When a circuit is open - current will not flow

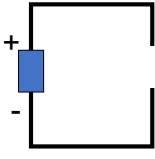

ASAA – Level 1 Course © ASAA 2023

Slide 6-6

6

General Electricity & Electronics

Circuit Symbols

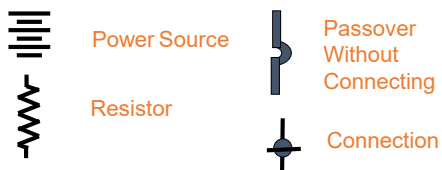

Power Source

Resistor

Passover Without Connecting

Connection

ASAA – Level 1 Course © ASAA 2023 Slide 6-7

7

Types of Circuits

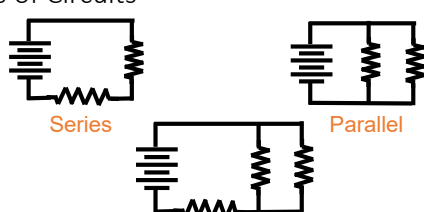

Series

Parallel

Series-Parallel or Combination

ASAA – Level 1 Course © ASAA 2023 Slide 6-8

8

Types of Circuits

Most commonly find:

- Burglary circuits (zones) – Series
- Robbery circuits – Parallel
- Fire circuits (zones) – Parallel
- Supervisory circuits – Parallel
- Power (auxiliary and all other)– Parallel
- Annunciation - Parallel

ASAA – Level 1 Course © ASAA 2023 Slide 6-9

9

Measuring Electricity

- **Voltage** = Motivation –Force- Pressure
 - Measured on Volts (V)
 - Symbol in equation is “E”
- **Current** = How much
 - Measured in Amps (A)
 - Symbol in equation is “I”
- **Resistance** = Obstacles
 - Measured in Ohms (Ω)
 - Symbol in equations “R”

ASAA – Level 1 Course © ASAA 2023 Slide 6-10

10

Sources of Resistance

- Anything that causes electrons to slow down;
 - smaller wire
 - longer wire lengths
 - splices
 - More components

ASAA – Level 1 Course © ASAA 2023 Slide 6-11

11

Ohm’s Law

- A mathematics equation that sums up the relationship between Resistance, Voltage and Current
- Can be used to calculate component values
- Can be used to find an unknown value. (Must know any two variables)

ASAA – Level 1 Course © ASAA 2023 Slide 6-12

12

Ohm's Law

- Can be mathematically manipulated to any of three formulas

$$E = I \times R = ? \text{Volts}$$
$$I = E \div R = ? \text{Amps}$$
$$R = E \div I = ? \text{Ohms}$$

ASAA – Level 1 Course © ASAA 2023 Slide 6-13

13

Ohm's Law Reminder

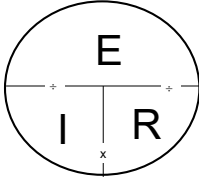

The Earth Is Round
Reminder of equations to solve for unknown

Rule of Thumb
Place thumb over unknown value

ASAA – Level 1 Course © ASAA 2023 Slide 6-14

14



Class Exercise



In a circuit if voltage stays the same and resistance increases-

What will happen to the amperage?

ASAA – Level 1 Course © ASAA 2023 Slide 6-15

15

General Electricity & Electronics

Exercise Answer

Resistance increases (doubles)



| | |
|---------|--------|
| E = 12V | |
| I = 3A | R = 4Ω |

| | |
|---------|--------|
| E = 12V | |
| I = ? | R = 8Ω |

What happens to Amperage (I)?
Did it increase? Decrease?

ASAA – Level 1 Course © ASAA 2023 Slide 6-16

16

 Class Exercise 

In a circuit if voltage stays the same the wire shorts (resistance decreases)-
What will happen to the amperage?

ASAA – Level 1 Course © ASAA 2023 Slide 6-17

17

Power = Watts = VA

- Is a value of the actual “work” being done by the electricity
- Is found by multiplying Volts times Amps (thus the VA)
- Is measured in Watts
- Symbol is “P”, “W” or “VA”

ASAA – Level 1 Course © ASAA 2023 Slide 6-18

18

Power Wheel

The same "Rule of Thumb" will work with Power.

ASAA – Level 1 Course © ASAA 2023 Slide 6-19

19

Units of Measurement

- Micro (μ) - One millionth- 0.000001
- Milli (m) - One thousandth- 0.001
- Kilo (K) - One thousand- 1000
- Mega (M) - One million- 1,000,000
- Giga (G) - One billion- 1,000,000,000
- Tera (T) - one trillion- 1,000,000,000,000

ASAA – Level 1 Course © ASAA 2023 Slide 6-20

20



Conversions

To convert from a "prefix" to a base unit, multiply by the value related to that prefix on the previous slide.

To convert from a base unit to a prefix, divide by the value related to that prefix on the previous slide.

ASAA – Level 1 Course © ASAA 2023 Slide 6-21

21

 Class Exercise 

How do you convert from the milliamp scale to the amp scale?

ASAA – Level 1 Course © ASAA 2023 Slide 6-22

22



Exercise Answer

We are converting from a prefix to a base unit. We will multiply the amount by the value related to the prefix.

Answer: We would multiply by 0.001

ASAA – Level 1 Course © ASAA 2023 Slide 6-23

23

 Class Exercise 

How do you convert from the volts scale to the millivolts scale?

ASAA – Level 1 Course © ASAA 2023 Slide 6-24

24



Exercise Answer

We are converting from a base unit to a prefix. We will divide the amount by the value related to the prefix.

Answer: We would divide by 0.001

ASAA – Level 1 Course © ASAA 2023 Slide 6-25

25

 Class Exercise 

How do you convert from the ohms scale to the kilo-ohm scale?

ASAA – Level 1 Course © ASAA 2023 Slide 6-26

26

Exercise Answer

We are converting from a base unit to a prefix. We will divide the amount by the value related to the prefix.

Answer: We would divide by 1,000

ASAA – Level 1 Course © ASAA 2023 Slide 6-27

27

EMI- Electro Magnetic Interference

- A disturbance that interrupts, obstructs, or otherwise degrades or limits performance
- Electrical interference may be caused by power lines or electrical equipment
- Can mask data signals on cabling and telephone lines

ASAA – Level 1 Course © ASAA 2023 Slide 6-28

28

Induction

- When magnetic flux lines cross into another conductor, current flow is generated within the separate conductor
- Effect is maximized by longer parallel conductors - more surface area
- Effect is minimized by crossing conductors at ninety degree angles - less surface area

ASAA – Level 1 Course © ASAA 2023 Slide 6-29

29

RFI- Radio Frequency Interference

- Signals from amateur radios, CBs, and radio and television stations
- Can interfere with data transmissions
- Can Block Radio signals

ASAA – Level 1 Course © ASAA 2023 Slide 6-30

30

Resistor

- Provides a specific amount of resistance
- Used to Control Current
- Resistor values can be determined
 - by using an Ohm-meter or
 - by reading the color bands.

Slide 6-31

31

Read the Resistor Color Code

Begin with the band closest to the end of the resistor (1st Value); this is the first digit of the resistance. In the example, the first band is brown and the color table lists brown as "1", so our first digit = 1. The second band is black, so it equals 0. The final band is the multiplier which is red. That makes the multiplier "10²" or "00". The resistor value would be 1.000 (1K) Ohms.

For instance
1st Value = 1
2nd Value = 0
and the multiplier = 00 (or multiply by 10²)

| 1 st Value | 2 nd Value | Multi-plier |
|-----------------------|-----------------------|-------------|
| 1 | 0 | 00 |
| or | | |
| 1,000 | | |

Tolerance Band: brown 1%, red 2%, gold 5%, silver 10%, no color 20%.

Slide 6-32

32

Color code

| Color | # | Multiplier | X | Color | # | Multiplier | X |
|--------|---|------------|-----------------|--------|---|---------------|-----------------|
| Black | 0 | X0 | 10 ⁰ | Green | 5 | X00,000 | 10 ⁵ |
| Brown | 1 | X0 | 10 | Blue | 6 | X000,000 | 10 ⁶ |
| Red | 2 | X00 | 10 ² | Violet | 7 | X0,000,000 | 10 ⁷ |
| Orange | 3 | X000 | 10 ³ | Gray | 8 | X00,000,000 | 10 ⁸ |
| Yellow | 4 | X0,000 | 10 ⁴ | White | 9 | X,000,000,000 | 10 ⁹ |

Tolerance Band gold 5% silver 10% no color 20%

Slide 6-33

33

Tolerance

- Tolerance band is located by itself at the opposite end of the resistor.
- Gives us variation that this particular resistor provides.
- A silver band resistor could vary from 900 to 1100 Ohms for example).

Tolerance Band: brown 1%, red 2%, gold 5%, silver 10%, no color 20%.

ASAA – Level 1 Course © ASAA 2023 Slide 6-34

34

Resistors Quiz

Let's try some examples:

In the Resistor R_1 above fill in the blanks for the 1st value, 2nd value, multiplier and tolerance.

| | | | |
|-----------|-----------|------------|------------|
| 1 | 1 | 0 | 5 % |
| 1st Value | 2nd Value | Multiplier | Tolerance |

What is the labeled resistor value?

ASAA – Level 1 Course © ASAA 2023 Slide 6-35

35

Resistors Quiz

What is the labeled resistor value?

What is the range (tolerance) of the resistor?

ASAA – Level 1 Course © ASAA 2023 Slide 6-36

36

Resistors Quiz

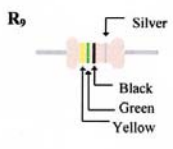

R_9

What is the labeled resistor value?

What is the range (tolerance) of the resistor?

ASAA – Level 1 Course © ASAA 2023 Slide 6-37

37

Capacitors

- Blocks the flow of D.C. while allowing A.C. to pass
- Can be used as filters
- Can store an electrical charge



ASAA – Level 1 Course © ASAA 2023 Slide 6-38

38

Diode (a Semiconductor)

- Equivalent to an electron “check valve”
- Allows current to flow in only one direction
- Can be used to rectify (convert) A.C. to D.C.

ASAA – Level 1 Course © ASAA 2023 Slide 6-39

39

Transistor (a Semiconductor)

- Can be used as an electrical switch
- Can be used to amplify a signal

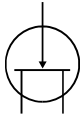

ASAA – Level 1 Course © ASAA 2023 Slide 6-40

40

Relay

- Is an electro-mechanical switch
- Can be used to electrically isolate circuits
- Coil is rated at a certain voltage
- Contacts are rated at a certain amperage

ASAA – Level 1 Course © ASAA 2023 Slide 6-41

41

Switches

- Used to Make and Break a circuit

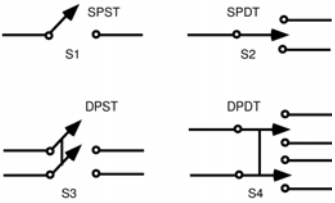

SPST = Single Pole, Single Throw
SPDT = Single Pole, Double Throw
DPST = Double Pole, Single Throw
DPDT = Double Pole, Double Throw

ASAA – Level 1 Course © ASAA 2023 Slide 6-42

42

Fuses and Circuit Breakers

- Interrupts circuit when amperage goes over a certain level
- Protects wiring and devices

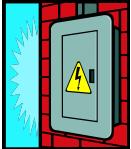

ASAA – Level 1 Course © ASAA 2023 Slide 6-43

43

Surge Protection

- Transorbs / Gas Tube / MOV's
- Arrest voltage spikes
- Are rated in volts and joules (similar to Watts)
- Shunt surges and spikes to ground
- **MUST HAVE A GROUND TO WORK!**



ASAA – Level 1 Course © ASAA 2023 Slide 6-44

44

Transformers

- Used to Reduce or Increase AC Voltage
- Rated by
 - Incoming Voltage
 - Output Voltage
 - Wattage or VA



ASAA – Level 1 Course © ASAA 2023 Slide 6-45

45

Standby Battery Calculation

- NFPA 72 requires 24 hours* of standby battery on all fire systems. It also requires at least 5 minutes power to all devices in alarm condition after the 24 hours of no power (4 minutes for residential, 15 minutes for voice evacuation).

*NFPA 72, 1999 edition and older require 60 hours of standby battery for remote station alarms.

Slide 6-46

46

Battery Calculation

Requirement – Per NFPA 72, National Fire Alarm Code, we must provide 24 hours of standby battery and then sound the alarm for 5 minutes.

| Device | Quantity | Standby Each | Alarm Each | Total |
|-----------------|----------|--------------|------------|-------|
| Control | 1 | 150mA | 220mA | |
| Keypad | 1 | 75mA | 120mA | |
| Motion Detector | 2 | 35mA | 75mA | |
| Smoke Detector | 2 | 45mA | 120mA | |
| Siren | 1 | - | 650mA | |
| Total | | | | |

Slide 6-47

47

Battery Calculation

Convert all values to base unit (Amps)

| Device | Quantity | Standby Each | Alarm Each | Total Standby/Alarm |
|-----------------|----------|--------------|---------------------|---------------------|
| Control | 1 | 150mA | | .15A |
| Keypad | 1 | 75mA | | .075A |
| Motion Detector | 2 | 35mA | | .07A |
| Smoke Detector | 2 | 45mA | | .09A |
| Siren | 1 | - | | - / |
| | | | Standby / Non-Alarm | .385A |

Slide 6-48

48

General Electricity & Electronics

Battery Calculation
Convert all values to base unit (Amps)

| Device | Quantity | Standby Each | Alarm Each | Total Standby/Alarm |
|-----------------|----------|--------------|------------|---------------------|
| Control | 1 | | 220mA | .22A |
| Keypad | 1 | | 120mA | .12A |
| Motion Detector | 2 | | 75mA | .15A |
| Smoke Detector | 2 | | 120mA | .24A |
| Siren | 1 | | 650mA | .65A |
| | | | Alarm | 1.38A |

ASAA – Level 1 Course © ASAA 2023 Slide 6-49

49

Battery Calculation

Requirement – Per NFPA 72, National Fire Alarm Code, we must provide 24 hours of standby battery and then sound the alarm for 5 minutes.

| | | | | |
|---------------------------------|-----------------|----------|---|------------------|
| Total Non-Alarm Current | .385A | X | 24 | 9.24 Ah |
| Total Alarm Current | 1.38A | X | .08333 | .115 Ah |
| Standby and Alarm | 9.24 Ah | + | .115 Ah | 9.355 Ah |
| Total Required Amp Hours | 9.355 Ah | X | 1.2 <small>De-rating factor</small> | 11.226 Ah |

ASAA – Level 1 Course © ASAA 2023 Slide 6-50

50

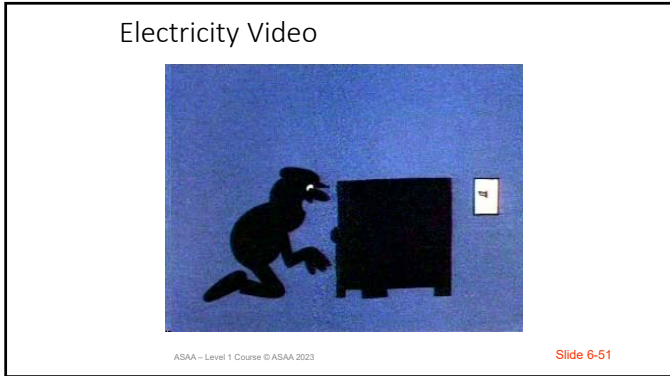

51

Tolerance

- Tolerance band is located by itself at the opposite end of the resistor.
- Gives us variation that this particular resistor provides.
- A silver band resistor could vary from 900 to 1100 Ohms for example).

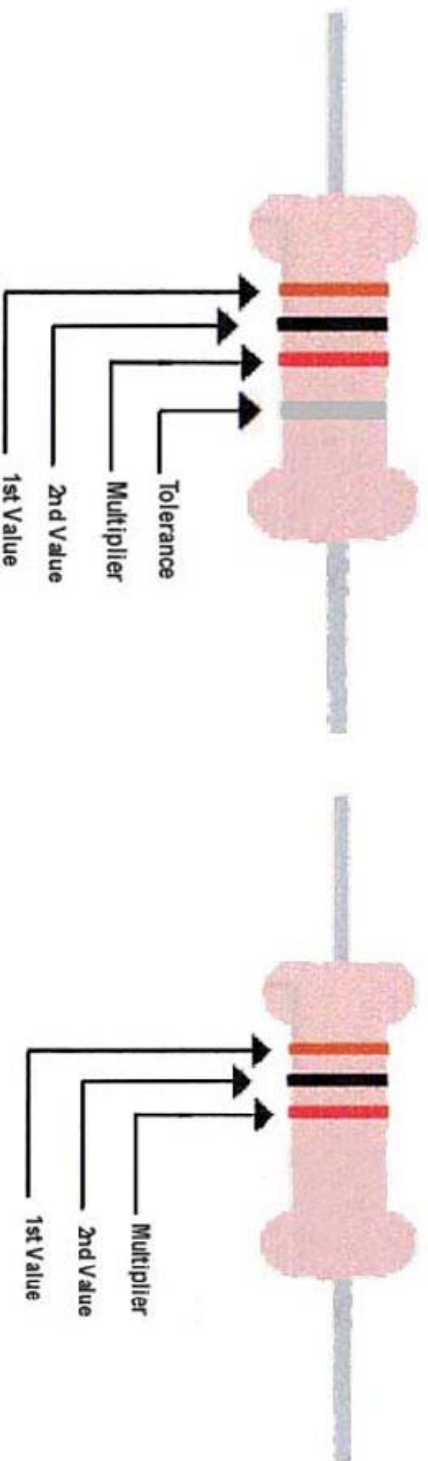

Tolerance Band: brown 1%, red 2%, gold 5%, silver 10%, no color 20%,

Computers & Networking



Arkansas Security Alarm Association
Arkansas Level 1

Computers & Networking

Chapter 7

ASAA -Level 1 Course © ASAA 2023 Slide 7-1

1

Computer Uses

- Control equipment
- Remote programming
- Sensor enhancement



ASAA -Level 1 Course © ASAA 2023 Slide 7-2

2

Network Uses

- Monitoring over the Internet
- Central Station Monitoring
- Interconnect to other systems



ASAA -Level 1 Course © ASAA 2023 Slide 7-3

3

Benefits

- Cross reference information
 - Allows operators to see information based on signal
 - Allow sensors to analyze signal vs. environment
- Expands options- Flexibility
 - Ability to program options for different situations

ASAA -Level 1 Course © ASAA 2023 Slide 7-4

4

Benefits

- Provides more information
 - logs
 - activity records
 - operator directions for each zone or site
- Reduces human error
 - Displaying appropriate information reduces error
 - Routine tasks can be automated

ASAA -Level 1 Course © ASAA 2023 Slide 7-5

5

Benefits

- Filter information
 - Only required info is shown
- Speeds response
 - Communication improved
 - Less time spent finding procedures
- Increases efficiency

ASAA -Level 1 Course © ASAA 2023 Slide 7-6

6

Disadvantages

- Complexity can add to troubleshooting time
- Requires increased training to diagnose or repair programs

ASAA -Level 1 Course © ASAA 2023 Slide 7-7

7

Surge Protection

- Computer equipment should be protected from
 - **Spikes** - a momentary sharp increase and fall in electric voltage or current
 - **Surges**- to rise suddenly to an excessive or abnormal value

ASAA -Level 1 Course © ASAA 2023 Slide 7-8

8

UPS –
Uninterruptible Power Supply

- Because computers store some items in RAM or temporary memory that will be lost if power is lost
- Continuous power is important
- Use battery backup and/or UPS systems



ASAA -Level 1 Course © ASAA 2023 Slide 7-9

9

LAN- Local Area Network

ASAA -Level 1 Course © ASAA 2023 Slide 7-10

10

WAN- Wide Area Network

ASAA -Level 1 Course © ASAA 2023 Slide 7-11

11

Internet Connection Options

Types of Internet Services

| DSL | CABLE | SATELLITE | FIBER |
|---|--|---|---|
| <p>Uses an existing 2-wire copper telephone line connected to your home so service is delivered at the same time as landline telephone service.</p> | <p>Through use of a cable modem, users can access the Internet over cable TV lines. Cable modems can provide extremely fast access to the Internet, making a cable connection a viable option.</p> | <p>In certain areas where broadband connection is not yet offered, a satellite Internet option may be available. Similar to wireless access, satellite connection utilizes a modem.</p> | <p>Uses light to transmit information across a color spectrum of glass cables. The speed of fiber optics varies depending on how close your ISP delivers a fiber Internet signal to your house.</p> |

#Broadband Search ASAA -Level 1 Course © ASAA 2023 Slide 7-12

12

Internet Backbone

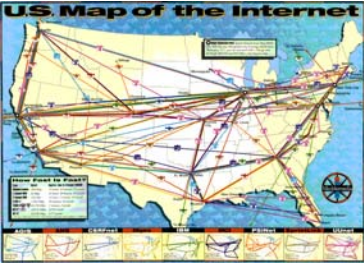

ASAA - Level 1 Course © ASAA 2023 Slide 7-13

13

DSL

- **Digital Subscriber Line** provides digital data transmission over the wires used in the "last mile" of a local telephone network.
- Download speed ranges from 128 kilobits per second (Kbps) to 24,000 Kbps



ASAA - Level 1 Course © ASAA 2023 Slide 7-14

14

Cable Modem

- Modulates a data signal over cable television infrastructure.
- Cable modems are primarily used to deliver broadband Internet access, taking advantage of unused bandwidth on a cable television network.



ASAA - Level 1 Course © ASAA 2023 Slide 7-15

15

Fiber Modem

- Modulates a data signal over newly run fiber optic cable.
- Fiber modems are primarily used to deliver broadband internet access over fiber optic cables dedicated for the use.



ASAA -Level 1 Course © ASAA 2023 Slide 7-16

16

Satellite Internet

- Internet access is even the most rural locations.
- Older services have severe latency



ASAA -Level 1 Course © ASAA 2023 Slide 7-17

17

Switch vs Router

- Switch that connects devices to form a Local Area Network (LAN).
- Router acts as a **junction between two networks** to transfer data packets among them.
- *Router is the intersection to connect to a street- Switch is the street – each house has a fixed address*



ASAA -Level 1 Course © ASAA 2023 Slide 7-18

18

Firewall

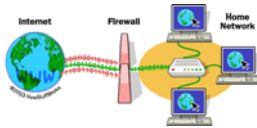

- Program or hardware device that filters the information coming through the Internet connection into your private network or computer system.
- If an incoming packet of information is flagged by the filters, it is not allowed through.

ASAA - Level 1 Course © ASAA 2023 Slide 7-19

19

Firewall Methods

- Firewalls use one or more of three methods to control traffic flowing in and out of the network:
 - **Packet filtering** - Packets (small chunks of data) are analyzed against a set of **filters**. Packets that make it through the filters are sent to the requesting system and all others are discarded.
 - **Proxy service** - Information from the Internet is retrieved by the firewall and then sent to the requesting system and vice versa.
 - **Stateful inspection** - Compares certain key parts of the packet to a database of trusted information. Information traveling from inside the firewall to the outside is monitored for specific defining characteristics, then incoming information is compared to these characteristics. If the comparison yields a reasonable match, the information is allowed through. Otherwise it is discarded.

ASAA - Level 1 Course © ASAA 2023 Slide 7-20

20

Firewalls Can Block

- Specific IP Address- e.g.:216.27.61.137
- Specific Domain Name e.g.: www.alarm.org
- Specific Protocols- e.g.: http, ip, smtp
- Specific Port numbers- e.g.: 80, 21
- Specific Words

ASAA - Level 1 Course © ASAA 2023 Slide 7-21

21

Getting thru the Firewall

- Add your IP Address, Domain Name, Protocols, Port numbers or Words to the approved list
- Or Remove it from the bad list

- List may be at the firewall or on the internet or both

ASAA -Level 1 Course © ASAA 2023 Slide 7-22

22

Internet Service Provider (ISP)

- Business or organization that offers users access to the Internet and related services.
- Provide services such as Internet transit, domain name registration and hosting, dial-up access, leased line access and colocation.
- Internet hosting services run servers, provide managed hosting, and include the Internet connection.

ASAA -Level 1 Course © ASAA 2023 Slide 7-23

23

IP Address

- Internet Protocol address
- A unique number that devices use in order to identify and communicate with each other on a network
- Used to route messages.

ASAA -Level 1 Course © ASAA 2023 Slide 7-24

24

IP Address Format

- 32-bit numeric address written as four numbers separated by periods.
- Each number can be zero to 255.
- Example, 67.160.10.240.

- *Think of it as your street address or internet telephone number*

ASAA –Level 1 Course © ASAA 2023 Slide 7-25

25

Assigning IP Addresses

- On an isolated network
 - you can assign IP addresses at random as long as each one is unique.
- Connecting to the Internet
 - requires using registered IP addresses to avoid duplicates.

- *Street address registered with Post Office so you get mail*

ASAA –Level 1 Course © ASAA 2023 Slide 7-26

26

Subnet

- Allows you to break down a single large network into smaller ones.
- Allows a single site to have a number of local area networks.

- *Like an apartment building with single address, but several apartment numbers or a phone system with extensions*

ASAA –Level 1 Course © ASAA 2023 Slide 7-27

27

Static or Dynamic Address

- Static
 - Address is assigned and remains until changed
- Dynamic
 - Address is assigned each time the computer or modem connects

ASAA – Level 1 Course © ASAA 2023 Slide 7-28

28

DHCP

- Dynamic Host Configuration Protocol
 - Lets network administrators centrally manage and automate the assignment of Internet Protocol (IP) addresses in an organization's network.
 - A unique IP address, which is assigned when an Internet connection is created for a specific computer.

ASAA – Level 1 Course © ASAA 2023 Slide 7-29

29

Ports

- Any server machine makes its services available to the Internet using numbered **ports**, one for each service that is available on the server.
- Clients connect to a service at a specific IP address and on a specific port.

- Common Port Numbers
 - echo 7
 - daytime 13
 - qotd 17 (Quote of the Day)
 - ftp 21
 - telnet 23
 - smtp 25 (Simple Mail Transfer, meaning e-mail)
 - time 37
 - nameserver 53
 - nickname 43 (Who Is)
 - gopher 70
 - finger 79
 - WWW 80

ASAA – Level 1 Course © ASAA 2023 Slide 7-30

30

Computers & Networking

Ping

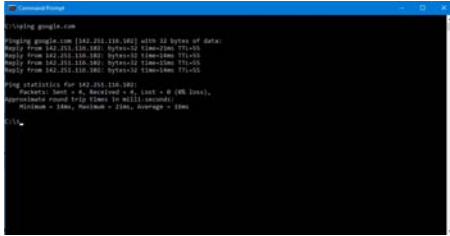

A DOS or Command Prompt tool allowing you to search for another device on a network.
Search by IP address or URL.

ASAA - Level 1 Course © ASAA 2023 Slide 7-31

31

Ipconfig

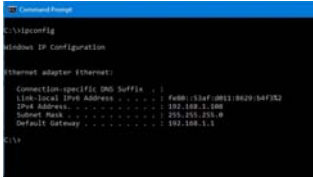

A DOS or Command Prompt tool allowing you to see the network configuration of the device on which you are working.

ASAA - Level 1 Course © ASAA 2023 Slide 7-32

32

Potential Internet Issues

- Unregulated
- No requirements for backup power
- Volume of traffic can delay or prevent data
- Multiple Service Providers involved in each communication –
 - Sender modem
 - Sender path
 - Sender ISP
 - Backbone
 - Recipient ISP
 - Recipient Path
 - Recipient Modem

ASAA - Level 1 Course © ASAA 2023 Slide 7-33

33

VoIP

- POTS connect directly to Telco
- Telco provides backup Power
- VoIP equipment needs its own backup
- Lost or delayed packets are not noticed for voice, but a problem for data

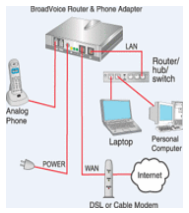

ASAA – Level 1 Course © ASAA 2023

Slide 7-34

Tools



Arkansas Security Alarm Association
Arkansas Level 1

Tools

Chapter 8

ASAA -Level 1 Course © ASAA 2023Slide 8-1

1

Quality

- Get the best quality you can afford
- Unreliable tools cost you time and money and can lead to damage to equipment and property
- Use tools for the intended purpose



ASAA -Level 1 Course © ASAA 2023Slide 8-2

2

Safety

- Know how each tool works
- Be aware of potential hazards
- Wear appropriate safety gear

ASAA -Level 1 Course © ASAA 2023Slide 8-3

3

Tools

Hand Tools

- Keep tools clean
- Discard if handles are splintered, chipped or broken
- Use the correct size
- When twisting, prying or swinging make sure the path is clear
- Sharpen cutting edges
- Oil hinges and moving parts



ASAA -Level 1 Course © ASAA 2023 Slide 8-4

4

Power Drills

- Use the correct bit
- Use a sharp bit
- Tighten the chuck
- Let the drill do the work
- Never use the trigger lock
- Avoid pressure
- Use both hands



ASAA -Level 1 Course © ASAA 2023 Slide 8-5

5

Fish Tapes

- Use fiberglass tapes when possible
- Know what is on the other end
- Pull a pull line first for multiple bends or cables
- Use gloves or grip tools when pulling the tape back to you



ASAA -Level 1 Course © ASAA 2023 Slide 8-6

6

Tools

Pull Rods

- Use fiberglass rods when possible
- Know what is on the other end



ASAA -Level 1 Course © ASAA 2023 Slide 8-7

7

Connection Tools

- Discard worn blades on punch tools
- Insulate metal blades when working on live lines
- Let the tool do the work do not use excess pressure



ASAA -Level 1 Course © ASAA 2023 Slide 8-8

8

Staple Gun

- Useful to fasten cable
- Avoid tight fit around cable



ASAA -Level 1 Course © ASAA 2023 Slide 8-9

9

Tools

Digital vs. Analog Meters

- Digital is much more durable and forgiving
- Analog is best for detecting “swingers”



ASAA –Level 1 Course © ASAA 2023 Slide 8-10

10

Test Equipment

- Set to measure what you want to measure, volts, amps, ohms
- Check the range setting to make sure you will not exceed it
- Power down when not in use



ASAA –Level 1 Course © ASAA 2023 Slide 8-11

11

Level

- Level is straight horizontally
- Plumb is straight vertically
- Dropping a level may move it out of alignment

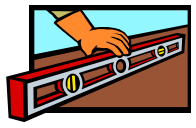

ASAA –Level 1 Course © ASAA 2023 Slide 8-12

12

Stud Finder

- Helpful to locate studs inside walls



ASAA –Level 1 Course © ASAA 2023 Slide 8-13

13

Smart Stud Finder

- Shows what is inside the wall...not just that something is there.



ASAA –Level 1 Course © ASAA 2023 Slide 8-14

14

Soldering/Desoldering Techniques

- Only use rosin core solder
- Keep the tip of the soldering iron or gun clean and tinned
- Clean the parts to be soldered



ASAA –Level 1 Course © ASAA 2023 Slide 8-15

15

Soldering/Desoldering Techniques

- Start with a strong mechanical joint.
- Use a properly sized soldering iron or gun
- Heat the parts to be soldered, not the solder



ASAA -Level 1 Course © ASAA 2023 Slide 8-16

16

Soldering/Desoldering Techniques

- Use only enough solder to fill all voids
- Keep everything absolutely still for the few seconds
- A good solder connection will be quite shiny - not dull gray or granular



ASAA -Level 1 Course © ASAA 2023 Slide 8-17

17

Prepare For System Installation



Arkansas Security Alarm Association

Arkansas Level 1

Prepare for System Installation

Chapter 9

ASAA – Level 1 Course © ASAA 2023Slide 9-1

1

Preparation Steps

- Conduct site survey
- Documentation
- Finalize sensors
- Select and locate control
- Select wiring paths
- Develop a job plan
- Preassemble
- Pretest

ASAA – Level 1 Course © ASAA 2023Slide 9-2

2



Arkansas Security Alarm Association

Arkansas Level 1

Section 9-1

Conduct Site Survey

ASAA – Level 1 Course © ASAA 2023Slide 9-3

3

Prepare For System Installation

Burglary System Survey

- Are customers worried about detection while at the location, or away?
(Motion detectors are usually disarmed while in stay mode)
- Are doors “tight” enough for magnetic contacts?
- Are windows moveable, fixed, or a mix of both?
- Will there be partitions/areas?

ASAA – Level 1 Course © ASAA 2023 Slide 9-4

4

Fire System Survey

- Who is the AHJ on this project?
- What fire code has been adopted?
- Are their requirements beyond existing local and state fire codes?
(insurance?)
- What occupancy classification?
- Is the building sprinkled?
- What if there are existing devices? (electrician installed smoke detectors)

ASAA – Level 1 Course © ASAA 2023 Slide 9-5

5

Access Control System Survey

- How many doors?
- How many users?
- What type of doors?
Are the doors sturdy?
Do they swing in or out?
- What type of computer resources will be available to administer the system?

ASAA – Level 1 Course © ASAA 2023 Slide 9-6

6

Prepare For System Installation

Camera System Survey

- How much light?
- How many cameras?
- How much archival information?
- How many frames/fields per second?
- Will there be remote access?
- What type of networking / IT resources are there?

ASAA – Level 1 Course © ASAA 2023 Slide 9-7

7

Keep it Simple

- Over complicated systems can lead to:
 - False Alarms
 - Service calls to explain operation
 - Dissatisfied customers

ASAA – Level 1 Course © ASAA 2023 Slide 9-8

8



Arkansas Security Alarm Association
Arkansas Level 1

Section 9-2

Documentation

ASAA – Level 1 Course © ASAA 2023 Slide 9-9

9

Prepare For System Installation

Disclaimer

- The forms used in this course are used for examples
- Significant legal language or items specific to you company requirements may not be included

ASAA – Level 1 Course © ASAA 2023 Slide 9-10

10

Contract or Agreement

- Full agreement on job requirements
- Legal language



ASAA – Level 1 Course © ASAA 2023 Slide 9-11

11

Work Order

Lists specific types of equipment and locations



ASAA – Level 1 Course © ASAA 2023 Slide 9-12

12

Prepare For System Installation

Change Order

Makes a change to a contract for a new system
Or
Makes a change to an existing system



ASAA – Level 1 Course © ASAA 2023 Slide 9-13

13

Parts List

Lists ALL the required parts



ASAA – Level 1 Course © ASAA 2023 Slide 9-14

14

Use Job Documentation to:

- Verify that equipment is appropriate
- Select locations
- Determine wiring requirements
- Select wiring paths

ASAA – Level 1 Course © ASAA 2023 Slide 9-15

15

Prepare For System Installation

Verify That Equipment Is Appropriate

- Is it possible to get wire between the control and all the devices?
- Will metal used in construction interfere with transmissions between devices?
- Does air flow, size, window placement, etc. rule out some types of sensors?

ASAA – Level 1 Course © ASAA 2023 Slide 9-16

16

Check Construction

- Drywall, Plaster, Brick, Cinderblock
- Drop ceiling, attics, crawlspaces, unfinished basements
- Check if closets on each level line up
- Look for a utility room
- Hardwood floors or carpeting
- Can molding be removed?

ASAA – Level 1 Course © ASAA 2023 Slide 9-17

17

How To Find The Construction Type

- Tap on the walls to see if they are hollow
- Remove a switch or outlet plate to see what is behind it
- Check the attic, basement or crawl space
- Ask the site owner

ASAA – Level 1 Course © ASAA 2023 Slide 9-18

18



Prepare For System Installation

Double Check

- Make sure that the system will work for the customer
- Do they have pets?
- Are all areas of concern covered?
- Can they live with the design?

ASAA – Level 1 Course © ASAA 2023 Slide 9-19



19

 Class Exercise 

What are some reasons that you changed a system design from what was on the documentation?

ASAA – Level 1 Course © ASAA 2023 Slide 9-20

20

 Class Exercise 

How did you handle making the change?

ASAA – Level 1 Course © ASAA 2023 Slide 9-21

21

Prepare For System Installation



Arkansas Security Alarm Association

Arkansas Level 1

Section 9-3

Finalize sensors

ASAA – Level 1 Course © ASAA 2023Slide 9-22

22



Arkansas Security Alarm Association

Arkansas Level 1

Section 9-3

Finalize sensors

Motion Detectors

ASAA – Level 1 Course © ASAA 2023Slide 9-23

23

Sensor Considerations

- Check the manuals for:
 - Coverage pattern of each sensor
 - Mounting requirements
 - Environmental requirements
 - Recommended locations

ASAA – Level 1 Course © ASAA 2023Slide 9-24

24

Prepare For System Installation

Sensor Location Considerations

- Exposure to direct solar radiation
- Exposure to natural drafts or artificial ventilation
- Likelihood of vibration induced by wind, traffic, pumps, etc.
- Types of surfaces, finishes and their ability to absorb and reflect

ASAA – Level 1 Course © ASAA 2023 Slide 9-25



25

Sensor Location Considerations

- Positioning to ensure proper operation (maximum coverage, minimal blockage)
- Proximity of radiant or convective heating appliances
- Proximity of air supply diffuser vents or air extract grills
- Possibility of normal human activity impacting the sensor

ASAA – Level 1 Course © ASAA 2023 Slide 9-26

26

 Class Exercise 

What are some common mistakes when locating Passive Infrared (PIR) sensors?

ASAA – Level 1 Course © ASAA 2023 Slide 9-27

27

Prepare For System Installation

PIR Location Considerations

- Avoid heating devices that will cause rapid temperature increase
- Avoid applications where the sensor pattern cannot terminate on a flat surface
- Avoid areas that will frequently be occupied by people or animals while system is armed

ASAA – Level 1 Course © ASAA 2023 Slide 9-28

28

PIR Location Considerations

- Mount on a stable wall or ceiling to avoid alarms caused by vibration
- Avoid directing at a window, heat source or reflected heat source
- PIRs react to “crosswalk”, not walking toward and away from the unit.

ASAA – Level 1 Course © ASAA 2023 Slide 9-29

29

Infrared Image of a Home

ASAA – Level 1 Course © ASAA 2023 Slide 9-30

30

Prepare For System Installation

Infrared Image of a Home

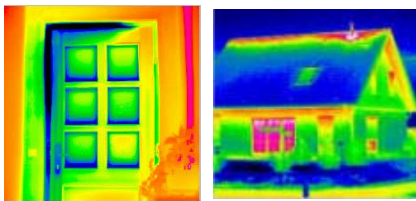

Inside A Front Door Outside A Home

ASAA – Level 1 Course © ASAA 2023 Slide 9-31

31

Possible Problems



A Coffee Maker A Plug in Air Freshener

ASAA – Level 1 Course © ASAA 2023 Slide 9-32

32

Possible Problems

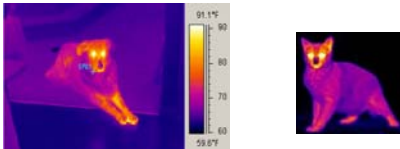

A Dog A Cat

ASAA – Level 1 Course © ASAA 2023 Slide 9-33

33

Prepare For System Installation

Possible Problems

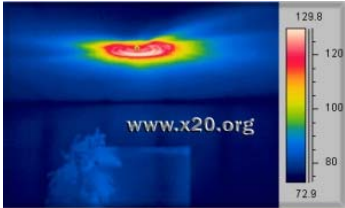

A Vent

ASAA – Level 1 Course © ASAA 2023 Slide 9-34

34

The Objective



ASAA – Level 1 Course © ASAA 2023 Slide 9-35

35

Dual Tech Motion Detectors

- Typically passive infrared and microwave technologies.
- Both must trip before alarm
- Used to reduce false alarms
- Less sensitive because movement must cross motion patter (PIR) and move toward and away from unit (microwave).

ASAA – Level 1 Course © ASAA 2023 Slide 9-36

36

Prepare For System Installation

Dual Tech Motion Detectors
Overhead view of patterns

ASAA – Level 1 Course © ASAA 2023 Slide 9-37

37

Testing Motion Detectors

- Follow manufacturer’s instructions
- Enable the walk test light
- Walk through premises, should not be able to take more than four (4) steps in the detection area without being “seen” or “caught” by the sensor
- Test as though a burglar
Crawl? Kneel?
- Make sure that device trips control and sends signal to the monitoring station

ASAA – Level 1 Course © ASAA 2023 Slide 9-38

38

Myth Busters

ASAA – Level 1 Course © ASAA 2023 Slide 9-39

39

Prepare For System Installation



Arkansas Security Alarm Association
Arkansas Level 1

Section 9-3

Finalize sensors Door Contacts

ASAA – Level 1 Course © ASAA 2023Slide 9-40

40

Contact Location Considerations

- Conceal contact if possible
- Conceal or protect wiring
- Check manufacturers instructions
- Ease of wiring
- Ease of mounting
- Detection ability
- Exposure to environment
 - Easier to service
 - Exposed to accidental damage

ASAA – Level 1 Course © ASAA 2023Slide 9-41

41

Contact Location Considerations

- Poorly fitting doors or windows and improper installation are the primary causes of false alarms.
- Extreme weather conditions which cause excessive movement of the door, window or access portal can cause a false alarm.
- Preferred mounting location is 12” or more from the frame toward the center of the door.



ASAA – Level 1 Course © ASAA 2023Slide 9-42

42

Prepare For System Installation

Contact Location Considerations

- Surface reed switches should be installed parallel to the magnet.
- “Wide gap” designation usually means a higher quality reed switch and a more powerful magnet.
- Installation of the reed in parallel to the magnet is preferred.
- Proper alignment and spacing from metallic materials is required.

ASAA – Level 1 Course © ASAA 2023 Slide 9-43

43

Surface or Recess

- **Surface** -Mounting on top of a surface
 - Faster
- **Recess**- Mounting in a hole drilled into a surface so that the object is flush with the top of the mounting surface
 - Neater
 - More secure

ASAA – Level 1 Course © ASAA 2023 Slide 9-44

44

Testing Door Contacts

- Follow manufacturer’s instructions
- Close door, make sure zone is clear on touchpad
- Open door, make sure zone shows open on touchpad
- Make sure that you cannot open the door far enough to access without the sensor opens
- Make sure that device trips control and sends signal to the monitoring station

ASAA – Level 1 Course © ASAA 2023 Slide 9-45

45

Prepare For System Installation



Arkansas Security Alarm Association

Arkansas Level 1

Section 9-3

Finalize sensors Glassbreak Detectors

ASAA – Level 1 Course © ASAA 2023Slide 9-46

46

Acoustic Glassbreak Locations

- The acoustical characteristics of the room in conflict with the sensor's performance specifications
- "Soft" acoustic rooms (e.g. carpeted with window drapery) that absorb vibration or by altering the acoustic characteristics of the "hard" room (e.g., adding window shutters, blinds, draperies, rugs) after the sensor has been tuned can cause detection inadequacy of the sensor
- Proper placement calibration and testing are required to avoid false alarms

ASAA – Level 1 Course © ASAA 2023Slide 9-47

47

Testing Glassbreak Detectors

- Follow manufacturer's instructions
- Use manufacturer's test device (simulates the sound of breaking glass)
- Make sure to test from each window that the detector is expected to trip. Make sure that curtains, blinds, and other window coverings are in their normal position when testing.
- Make sure that device trips control and sends signal to the monitoring station

ASAA – Level 1 Course © ASAA 2023Slide 9-48

48

Prepare For System Installation



Arkansas Security Alarm Association

Arkansas Level 1

Section 9-3

Finalize sensors Outdoor Sensors

ASAA – Level 1 Course © ASAA 2023Slide 9-49

49

Considerations for Outdoor Sensors

- Presence of grass or vegetation
- Possibility of leaf accumulation
- Possibility of movement of branches
- Likelihood of snow accumulation
- Possibility of fog, mist or dust.
- Occurrence of lightning.
- Check manufacturer’s recommendations

ASAA – Level 1 Course © ASAA 2023Slide 9-50

50

Testing Outdoor Sensors

- Follow manufacturer’s instructions
- Make sure that device trips control and sends signal to the monitoring station



ASAA – Level 1 Course © ASAA 2023Slide 9-51

51

Prepare For System Installation



Arkansas Security Alarm Association

Arkansas Level 1

Section 9-3

Finalize sensors Fire Sensors

ASAA – Level 1 Course © ASAA 2023Slide 9-52

52

The Fire Threat - 2021

- 2620 Civilian Fire Deaths in US Homes
- Every 24 Seconds a fire department responds to a fire somewhere in the US
- Residential Fire occurs every 82 seconds
- \$11.6 Billion in Property Loss

Source NFPA

ASAA – Level 1 Course © ASAA 2023Slide 9-53

53

Smoke Detector Locations

- One outside each sleeping area
- One on each full level
- In new construction, smoke alarms are also required in every sleeping room
- Wall mounted detectors shall be no further than 12 inches below the ceiling

ASAA – Level 1 Course © ASAA 2023Slide 9-54

54

Prepare For System Installation

Spot-Type Smoke Detector Locations

- On a sidewall, portion at or above 12 in. down from the ceiling to the top of the detector.

Text: NFPA 72 17.7.3.2.1

ASAA – Level 1 Course © ASAA 2023

Slide 9-55

55

Smoke Detector Locations

- Not in kitchens, garages, spaces where temp may fall below 40° or above 100°
- No closer than 3 ft from:
 - Door to kitchen
 - Door to bathroom with tub or shower
 - Supply register

ASAA – Level 1 Course © ASAA 2023

Slide 9-56

56

Photoelectric Smoke Detector Normal Situation

- Pulsed Light sent into Chamber
- Normally avoids Sensor

ASAA – Level 1 Course © ASAA 2023

Slide 9-57

57

Prepare For System Installation

Photoelectric Smoke Detector

- Smoke reflects light into the source
- Causes Alarm

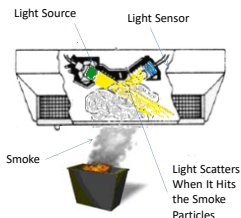

ASAA – Level 1 Course © ASAA 2023

Slide 9-58

58

Ionization Smoke Detector

- Air in chamber ionized to conduct current
- Smoke disrupts current flow



ASAA – Level 1 Course © ASAA 2023

Slide 9-59

59

Ionization Smoke Detector Normal Situation

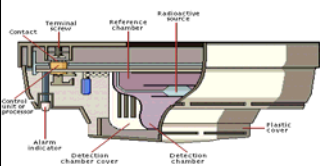

Current Flows Thru Chamber

Current Flows

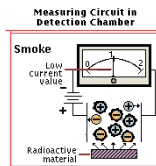

ASAA – Level 1 Course © ASAA 2023

Slide 9-60

60

Prepare For System Installation

Ionization Smoke Detector
Normal Situation- Alarm

Current Blocked

Measuring Circuit in Detection Chamber

Smoke

Low current value

Smoke attached to particles

Radioactive material

ASAA – Level 1 Course © ASAA 2023 Slide 9-61

61

Ionization Smoke Detector
Dual Chamber Detector

- Reference chamber added to adapt to environment and reduce false alarms

REFERENCE CHAMBER

SENSING CHAMBER

TINY HOLE OPENINGS

LARGE HOLE OPENINGS

ASAA – Level 1 Course © ASAA 2023 Slide 9-62

62

Heat Detector Locations

- Where smokes are not appropriate

ASAA – Level 1 Course © ASAA 2023 Slide 9-63

63

Prepare For System Installation

Fire Notification Appliances

- Clearly audible over background noise with all intervening doors closed (75db at the pillow)
- New construction- Activating one detector shall cause alarm to sound in all detectors
- If household has one hearing impaired occupant, visible signal required



ASAA – Level 1 Course © ASAA 2023 Slide 9-64

64

Fire Notification Appliances

- Commercial fire notification devices must be 15 dBA above ambient noise levels in all occupiable spaces.
- Noise levels above 105 dBA will require a visual device.
- Anytime more than two visuals can be seen, they must be synchronized.

ASAA – Level 1 Course © ASAA 2023 Slide 9-65

65

Class Exercise

Where would you mount smoke detectors?

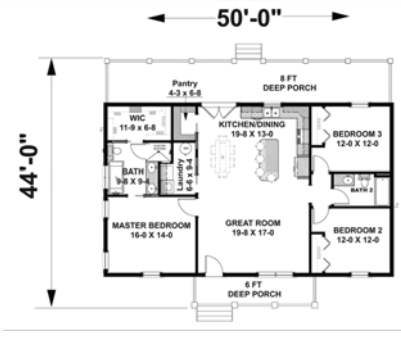

ASAA – Level 1 Course © ASAA 2023 Slide 9-66

66

Prepare For System Installation

Answer

One inside each sleeping area
One outside each sleeping area between the sleeping area and the rest of the house.

Be careful to stay 3' away from the bathroom, kitchen and any air diffusers. Verify that one sounder or sounder bases are sufficient for 75dBA at the pillow.

ASAA – Level 1 Course © ASAA 2023 Slide 9-67

67

Other considerations

- Kitchen heat detectors
- Laundry room heat detectors
- Heat detectors in the attic, especially if wooden shingles
- Is there a fireplace?
- Detection in garage?

ASAA – Level 1 Course © ASAA 2023 Slide 9-68

68

Class Exercise

Where would you mount smoke detectors?

ASAA – Level 1 Course © ASAA 2023 Slide 9-69

69

Prepare For System Installation

Answer

Be careful to stay 3' away from the bathroom, kitchen and any air diffusers. Verify that two sounders are sufficient for 75dBA at the pillow.

ASAA – Level 1 Course © ASAA 2023 Slide 9-70

70

Other Considerations

Smoke detectors in every suitable room. Heat detectors in rooms/area not suitable, such as kitchens, utility rooms, attic, garages, etc.

ASAA – Level 1 Course © ASAA 2023 Slide 9-71

71

Testing Fire Devices

- Follow manufacturer's instructions
- Testing smoke detectors may include using a magnet to draw an obstruction into the smoke sensor chamber. May also include using canned smoke to functionally test the detector (this is NOT a calibrated sensitivity test)
- Make sure that device trips control and sends signal to the monitoring station

ASAA – Level 1 Course © ASAA 2023 Slide 9-72

72

Prepare For System Installation



Arkansas Security Alarm Association

Arkansas Level 1

Section 9-3

Finalize sensors Access Control Devices

ASAA – Level 1 Course © ASAA 2023Slide 9-73

73

Access Control Doors

- Special Hardware may be required for certain doors.



L Bracket Z Bracket



Door Strike for
In-swinging
Door

ASAA – Level 1 Course © ASAA 2023Slide 9-74

74

Access Control Doors

- How much force will the magnet need to withstand?
Can the door withstand more?



1200 pound mag-lock



Dual 600 pound
mag-locks

ASAA – Level 1 Course © ASAA 2023Slide 9-75

75

Prepare For System Installation

Access Control System

- Will the customer need to track or count people accessing or egressing the facility?



ASAA – Level 1 Course © ASAA 2023 Slide 9-76

76

Anti-passback

- Feature that will not allow any access/egress credential to enter again unless it has been used to exit.
- Used to keep employees from handing their credential to someone else.



ASAA – Level 1 Course © ASAA 2023 Slide 9-77

77

Access Control & Fire Systems

NFPA 72 requires access control doors to unlock upon receipt of a fire signal OR within 10 minutes of the loss of power to the fire alarm system.



ASAA – Level 1 Course © ASAA 2023 Slide 9-78

78

Prepare For System Installation

Access Control System Administration

- Who will be responsible for enrolling and deleting credentials?
- How will those credentials be added and deleted?



ASAA – Level 1 Course © ASAA 2023 Slide 9-79

79

Control Equipment

- Central or On Line Processing – Systems where all systems information is stored in a central location and all go or no-go decisions are made by this unit
- Distributed Processing – Systems where some of the system information is stored at the individual readers or controllers.

ASAA – Level 1 Course © ASAA 2023 Slide 9-80

80

Control Equipment

- Degraded Mode – Feature of an access control system which allows a card reader to operate independently of the system's central control unit.

ASAA – Level 1 Course © ASAA 2023 Slide 9-81

81

Prepare For System Installation



Arkansas Security Alarm Association

Arkansas Level 1

Section 9-3

Finalize sensors Surveillance Devices

ASAA – Level 1 Course © ASAA 2023Slide 9-82

82

Camera Types





- Board
- Bullet resistant
- Covert
- Dome



- Bullet
- Hi-def day/night



- Full body



ASAA – Level 1 Course © ASAA 2023Slide 9-83

83

Camera Lighting

One Foot Candle

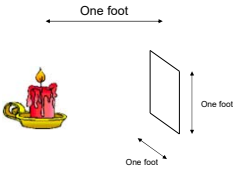

One foot

One Lux

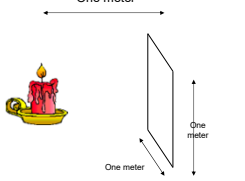

One meter

ASAA – Level 1 Course © ASAA 2023Slide 9-84

84

Prepare For System Installation

Camera Lighting

Typical Light Levels in Lux

| | |
|----------------|--------------------|
| .01 New Moon | 500 Typical Office |
| .1 Full Moon | 500 Libraries |
| 5 Street Light | 750 Supermarket |
| 10 Twilight | 20,000 Cloudy Day |
| 150 Warehouse | 100,000 Sunny Day |

ASAA – Level 1 Course © ASAA 2023 Slide 9-85

85

Resolution

- All NTSC cameras (composite) are limited to 525 lines of vertical resolution
Only 480 lines are actually displayed
- Lines are interlaced (shows every other line). This is called a field. Two fields make up a frame.

ASAA – Level 1 Course © ASAA 2023 Slide 9-86

86

Fields vs. Frames

Two fields of 272.5 lines are interlaced for a 525 line frame.



Only 480 lines are visible.

Progressive scan has no interlacing.

ASAA – Level 1 Course © ASAA 2023 Slide 9-87

87

Prepare For System Installation

Resolution Chart

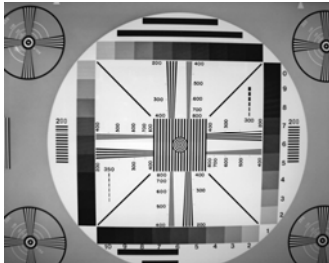

ASAA – Level 1 Course © ASAA 2023 Slide 9-88

88

Resolution

- There are also high definition (mega-pixel) cameras.
- A pixel is a dot on a computer screen. It is the smallest element of data in a video image.

• Common resolutions:

| | | |
|-------------|-------------|------------------|
| 720 x 480 | 1280 x 1024 | 4K = 3840 x 2160 |
| 800 x 600 | 1280 x 720 | 8K = 7680 x 4320 |
| 1024 x 768 | 1600 x 1200 | |
| 1920 x 1080 | | |

ASAA – Level 1 Course © ASAA 2023 Slide 9-89

89

Mega-pixel Camera

- High definition cameras have much higher resolution than NTSC.



ASAA – Level 1 Course © ASAA 2023 Slide 9-90

90

Prepare For System Installation

Lens

- Focal length is distance between imaging device (chip) and the lens. The smaller the number (4mm) the wider angle. The larger the number (75mm) the more tele-photo.

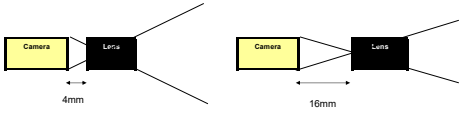

ASAA – Level 1 Course © ASAA 2023 Slide 9-91

91

Lens

- How to find out what size lens is needed?



Lens Wheel **Range Finder** **Web-site**

ASAA – Level 1 Course © ASAA 2023 Slide 9-92

92

Mounts

- Indoor or Outdoor
- Light, Medium, or Heavy Duty
- Dome or Breadbox
- Heated / Cooled / Wipers / Washers
- Bullet Resistant
- Explosion Proof

ASAA – Level 1 Course © ASAA 2023 Slide 9-93

93

Prepare For System Installation

Camera Mounts



ASAA – Level 1 Course © ASAA 2023 Slide 9-94

94



Monitors

LED monitors are liquid crystal displays (LCDs) that use light-emitting diodes (LEDs) to light the screen's pixels.

LED monitors use an array of efficient LEDs to light up the pixels.

ASAA – Level 1 Course © ASAA 2023 Slide 9-95

95

Recording

- How many frames (fields) per second?
 - 24 frames per second – Motion Pictures
 - 16 frames per second – Home Movies
 - 60 flickers per second – incandescent bulb
 - 30 frames per second – typical for audio recordings

Real time = ?

ASAA – Level 1 Course © ASAA 2023 Slide 9-96

96

Prepare For System Installation

Recording

- Video Cassette Recorder (VCR)– Magnetic recorder which records live CCTV picture with sound onto a cassette containing magnetic tape.

| | |
|--------------------|-----------------------------------|
| Advantages: | Disadvantages: |
| - Inexpensive | - High maintenance |
| - Easy to operate | - Searching can be time consuming |
| | - Tapes are limited to use(s) |
| | - Non-networkable |

ASAA – Level 1 Course © ASAA 2023 Slide 9-97

97

Recording

- Digital Video Recorder (DVR)– Computer based recorder that holds video and/or audio files on a hard drive. Cameras / microphones tie directly to DVR. A good VCR replacement.

| | |
|------------------------------------|--------------------------------------|
| Advantages: | Disadvantages: |
| -Inexpensive | - Computer based (hard drive issues) |
| - Easy to operate | - More user training |
| - Easy to search for archived data | |
| - Networkable | |

ASAA – Level 1 Course © ASAA 2023 Slide 9-98

98

Recording

- Network Video Recorder (NVR)– Computer based recorder that holds video and/or audio files on a hard drive. Cameras / microphones tie to same network that NVR is tied to.

| | |
|------------------------------------|--------------------------------------|
| Advantages: | Disadvantages: |
| -Inexpensive | - Computer based (hard drive issues) |
| - Easy to operate | - Dependant on network |
| - Easy to search for archived data | - More user training |
| - Networkable | |

ASAA – Level 1 Course © ASAA 2023 Slide 9-99

99

Prepare For System Installation

Archiving

- How long does the customer want to be able to view past events?
- For VCRs:

| Hours | FPS |
|-------|------|
| 2 | 60 |
| 6 | 20 |
| 12 | 10 |
| 24 | 5 |
| 48 | 2.5 |
| 72 | 1.3 |
| 168 | .7 |
| 960 | .125 |



ASAA – Level 1 Course © ASAA 2023 Slide 9-100

100

Archiving

- For Digital Video Recorders (DVR) and Network Video Recorders (NVR), length is based on resolution of each image, the ability to record based on pixel change, and the compression of the video files.
- Check with manufacturer for file size.

ASAA – Level 1 Course © ASAA 2023 Slide 9-101

101



Arkansas Security Alarm Association
Arkansas Level 1

Section 9-4

Select & Locate Control

ASAA – Level 1 Course © ASAA 2023 Slide 9-102

102

Prepare For System Installation

Selecting the Control

- Number of sensors
- Number of sensor locations
- Types of sensors
- Need for partitions
- Power requirements
- Ability to get wires to each sensor

ASAA – Level 1 Course © ASAA 2023 Slide 9-103

103

Zoned Panel or Point ID

- Zoned panels will give you a specific number of circuits
- Point ID or addressable panels will identify each device individually

ASAA – Level 1 Course © ASAA 2023 Slide 9-104

104

Decide on Zones

You will need at least one zone for each type of device:

- Entry Exit
- Perimeter Instant
- Interior and/or Interior Follower
- Fire Manual
- Fire Automatic
- Panic or Silent Holdup
- Environmental
 - Flood
 - Cold
 - Heat
 - Gas

ASAA – Level 1 Course © ASAA 2023 Slide 9-105

105

Prepare For System Installation

Add Zones for Locations

Breaking large numbers of sensors or large areas into separate zones will help reporting and troubleshooting

ASAA – Level 1 Course © ASAA 2023 Slide 9-106

106

Partitions

If separate areas need to be controlled individually - partitions or additional panels may need to be added

Ex: maid or guest rooms, separate areas of businesses

ASAA – Level 1 Course © ASAA 2023 Slide 9-107

107

Calculate Power Requirements

- Check manuals for power (amps) used by each device
- Remember to use a common scale
 - Convert everything to amps or milliamps
- Remember the keypad(s), the audible device(s) motion and glass break sensors
- Add up all devices to find your total requirements

ASAA – Level 1 Course © ASAA 2023 Slide 9-108

108

Prepare For System Installation

Wired or Wireless

- If you are unable to get wires to each sensor, wireless controls are the best bet
- If you can wire to any device, either option will do
- If you can wire to some locations and not others, hybrid controls with wireless and wired capability are an option

ASAA – Level 1 Course © ASAA 2023 Slide 9-109

109

Locate Central /Main Components

- Check manufacturer’s recommendations
- Range of temperature
- Range of humidity
- Degree of dust or dirt laden air

ASAA – Level 1 Course © ASAA 2023 Slide 9-110

110

Locate Central /Main Components

- Position to ensure continued access for adjustment or repair
- Position to reduce attack or tampering
- Protect from accidental physical damage
- Avoid sources of EMI- Electromagnetic Interference (transformers, radio transmitters)

ASAA – Level 1 Course © ASAA 2023 Slide 9-111

111



Prepare For System Installation

Control Location Considerations

- Visibility of devices
- Accessibility to unauthorized personnel
- Difficulty of installation
- Difficulty of connection to power and communication wiring
- Difficulty of connection to sensor wiring

ASAA – Level 1 Course © ASAA 2023 Slide 9-112

112

 Class Exercise 

Where do you usually put the control and why?

ASAA – Level 1 Course © ASAA 2023 Slide 9-113

113

Locating (Security) Audible Devices

- Audibility
- Conceal if possible
- Accessibility to unauthorized personnel
- Difficulty of installation
- Difficulty of connection to control
- Check manufacturer’s recommendations



ASAA – Level 1 Course © ASAA 2023 Slide 9-114

114

Prepare For System Installation

Locating Transformers

- Accessibility to unauthorized personnel
- Range of temperature
- Difficulty of installation
- Difficulty of connection to control
- Avoid GFCI circuits
- Check manufacturer's recommendations



ASAA – Level 1 Course © ASAA 2023 Slide 9-115

115

Locating Remote Keypads

- Proximity to entry-exit doors
- Accessibility to unauthorized personnel
- Difficulty of installation
- Difficulty of connection to control
- Check manufacturer's recommendations



ASAA – Level 1 Course © ASAA 2023 Slide 9-116

116



Arkansas Security Alarm Association
Arkansas Level 1

Section 9-5

Select wiring paths

ASAA – Level 1 Course © ASAA 2023 Slide 9-117

117

Prepare For System Installation

Wiring Methods

- **Home Run**- a wire is run from each device to the control
- **Common Loop**- wire is run to several locations from the control
- **Splice box**- wires are run from each device to a splice box where they connect to a common wire or a multiconductor cable

ASAA – Level 1 Course © ASAA 2023 Slide 9-118

118

Standards for Wiring

- National Electrical Code
- Manufacturer’s instructions for each device

ASAA – Level 1 Course © ASAA 2023 Slide 9-119

119

Commercial Wiring Paths

- Telecom/data closets/spaces can provide a path between levels
- Drop ceilings
- Raised floors
- Interior walls are often hollow



ASAA – Level 1 Course © ASAA 2023 Slide 9-120

120

Prepare For System Installation

Residential Wiring Paths

- Closets can provide a path between levels
- Attics
- Unfinished basements
- Crawl spaces
- Interior walls are often hollow
- Under carpet
- Behind molding
- Drop ceilings
- Area around return vents or plumbing chases

ASAA – Level 1 Course © ASAA 2023 Slide 9-121

121

Unacceptable Paths

- Elevator shafts
- Inside vents
- Attached to hot water pipes
- Attached to sprinkler pipes
- Attached to gas pipes

ASAA – Level 1 Course © ASAA 2023 Slide 9-122

122

Protecting Wiring

Exposed surface wiring can be protected with:

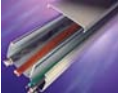

Wiremold



Conduit



Greenfield

ASAA – Level 1 Course © ASAA 2023 Slide 9-123

123

Prepare For System Installation

Splices & Connections

- Solid Connections are Critical
 - Punch down blocks
 - Terminal strips
 - Crimp type solderless connections
 - Wirenuts
 - Soldering

ASAA – Level 1 Course © ASAA 2023 Slide 9-124

124

Wire Types

- Wire varies by
 - Conductor size (AWG)
 - Type of insulation or jacket
 - Solid or Stranded
 - Shielded or not
 - Type of stranding to match bandwidth

ASAA – Level 1 Course © ASAA 2023 Slide 9-125

125

AWG

- American Wire Gauge
 - Indicates the diameter or cross section of a conductor
 - Represents current carrying limitations due to resistance
 - Lower the number the thicker the wire

ASAA – Level 1 Course © ASAA 2023 Slide 9-126

126

Prepare For System Installation

Wire Categories

- Level 1 = Plain Old Telephone Service (POTS)
- Level 2 = IBM Type 3 cabling system
- Cat 3 = 16 MHz (10 Mbps) 100 Ohm UTP
- Cat 4 = 20 MHz (16 Mbps) 100 Ohm UTP
- Cat 5 = 100 Mhz (100 Mbps) 100 Ohm UTP
- Cat 5e = 1000 Mhz (100 Mbps)
- Cat 6 = 250 Mhz (10 Gbps)
- Cat 6A = 500 Mhz (10 Gbps)
- Cat 7 = 600 Mhz (10 Gbps)

ASAA – Level 1 Course © ASAA 2023 Slide 9-127

127

Length : Resistance

- NFPA-70, the National Electric Code provides information about the amount of resistance per 1000' of a conductor based on its gauge size

ASAA – Level 1 Course © ASAA 2023 Slide 9-128

128

Resistance Adds Up

- Wire Resistance is more critical for power consuming devices
 - Main wire from transformer to control
 - Wire from control to audible devices
 - Wire from control to remote keypads
 - Ground wire
- Read the manufacturers instructions or call if not listed

ASAA – Level 1 Course © ASAA 2023 Slide 9-129

129

Prepare For System Installation

Solid vs. Stranded

- **Solid** indicates a single strand of a particular gauge conductor
 - More rigid / less flexibility
 - More susceptible to breakage
- **Stranded** indicates multiple strands composing a single conductor
 - More flexible
 - Less likely to break when nicked or bent

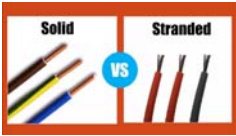

ASAA – Level 1 Course © ASAA 2023 Slide 9-130

130

Shielded

- An overall metallic covering over the conductors
- More costly
- Much more immune to RFI & EMI
- Shield must be connected to a ground source to work (typically at one end only)
- A must if required by manufacturer's installation instructions



ASAA – Level 1 Course © ASAA 2023 Slide 9-131

131

Jacketed

- An overall protective covering for two or more conductors
- Adds a second insulation layer
- Takes the abuse of installation instead of the conductor insulation
- Helps prevent ground faults and short circuits
- Provides additional tensile strength to the cable



Example of unjacketed wire

ASAA – Level 1 Course © ASAA 2023 Slide 9-132

132

Prepare For System Installation

Twisted

- Each pair of conductors within the same jacket are twisted independently from other conductors
- Greatly reduces EMI and induction
- Greatly reduces induction between pairs within the same cable



ASAA – Level 1 Course © ASAA 2023 Slide 9-133

133

Impedance

- A wire specification applying primarily to coax cables
- Typically 75Ω for CCTV and LAN wiring.
- Can affect picture quality
- Can affect data reliability if incorrect

ASAA – Level 1 Course © ASAA 2023 Slide 9-134

134

Radio Frequency Interference

- Comes from transmitters on a nearby frequency
- Comes from a more powerful source
- Can cause wireless systems to false alarm or “jam” a modules transmission to the panel, causing no alarm or supervisory
- Perform placement tests on each transmitter in a wireless system as per manufacturer’s instructions

ASAA – Level 1 Course © ASAA 2023 Slide 9-135

135

Prepare For System Installation

EMI

- Electro-magnetic Interference- Sources:
 - Switching of loads
 - Radio and TV broadcasts
 - Poor grounding
 - Lightning
 - Heavy equipment operations
 - Electric motors close to sensitive electronics

ASAA – Level 1 Course © ASAA 2023 Slide 9-136

136



Arkansas Security Alarm Association
Arkansas Level 1

Section 9-6

Develop a job plan

ASAA – Level 1 Course © ASAA 2023 Slide 9-137

137

Job Plan Considerations

- Job documentation
- What you learn on the survey
- Existing building or under construction?
- Availability of work site
- Availability of equipment

ASAA – Level 1 Course © ASAA 2023 Slide 9-138

138

Prepare For System Installation

Job Plan Considerations

- Sequence -is one item required for another?
- Availability of workforce
- Permit or inspection requirements
- Schedule of other trades
- Weather
- Access to job site

ASAA – Level 1 Course © ASAA 2023 Slide 9-139



139

Common Trades

- General Contractors
- Electricians
- Plumbers
- Carpenters

ASAA – Level 1 Course © ASAA 2023 Slide 9-140

140

 Class Exercise 

Name some challenges you have had with other trades on jobs

ASAA – Level 1 Course © ASAA 2023 Slide 9-141

141

Prepare For System Installation



Arkansas Security Alarm Association

Arkansas Level 1

Section 9-7

Preassemble

ASAA – Level 1 Course © ASAA 2023Slide 9-142

142

Complete pre-assemblies & fabrication of sub systems

- Review instructions
- Assemble devices as much as possible before installation
- Mount back boards
- Install mounting brackets

ASAA – Level 1 Course © ASAA 2023Slide 9-143

143



Arkansas Security Alarm Association

Arkansas Level 1

Section 9-8

Pretest

ASAA – Level 1 Course © ASAA 2023Slide 9-144

144

Prepare For System Installation

Pre-test Components

- Check wiring for continuity (complete circuit)
- Check for grounds
- Verify available voltage
- Check instructions for applicable tests

ASAA – Level 1 Course © ASAA 2023 Slide 9-145

145

Wireless Systems



Arkansas Security Alarm Association
Arkansas Level 1

Wireless Systems

Chapter 10

ASAA – Level 1 Course © ASAA 2023

Slide 10-1

1

Wireless Systems



- Typically refers to initiating devices communicating to the control panel via radio frequencies

ASAA – Level 1 Course © ASAA 2023

Slide 10-2

2



Arkansas Security Alarm Association
Arkansas Level 1

Section 10-1

Wireless Alarm Components

ASAA – Level 1 Course © ASAA 2023

Slide 10-3

3

Wireless Systems

When Should I Use Wireless Transceivers?

- When a wired connection is not an option
- When the cost of pulling wire is equal to or more than the cost of the required transmitting and receiving equipment
- May allow the job to be completed with less labor to offset the cost of additional equipment
- Some systems allow you to use whichever method is most cost effective on the same system

ASAA – Level 1 Course © ASAA 2023 Slide 10-4

4

Typical Range

- Depends on the construction of the building and the equipment used
- Most manufacturers cite a typical outdoor line of sight range of up to 1000 feet and a range inside the building from 300 to 500 feet
- Because the RF signals will penetrate wood, concrete and stone, but not metal, the range will vary from building to building and perhaps within the building

ASAA – Level 1 Course © ASAA 2023 Slide 10-5

5

How Can I Be Sure the Equipment Is Going To Work?

- Temporarily install the equipment you will use is the most effective way to know for sure
- Testing after the building construction is completed

ASAA – Level 1 Course © ASAA 2023 Slide 10-6

6

Wireless Systems

How Do Systems Vary?

- Systems use a variety of antennas to focus the signals and most use either the 900 Mhz or 2.4 Ghz frequencies to communicate.
- Because both of these frequency ranges are used by other devices, some manufacturers use spread spectrum technology to reduce interference and also reduce the chance of illegal monitoring



ASAA – Level 1 Course © ASAA 2023 Slide 10-7

7

Spread Spectrum

- Form of wireless communications in which the frequency of the transmitted signal is deliberately varied to provide greater bandwidth and also reduces the impact of interference

ASAA – Level 1 Course © ASAA 2023 Slide 10-8

8

Signal Blocking

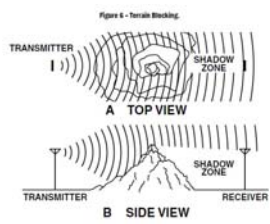

ASAA – Level 1 Course © ASAA 2023 Slide 10-9

9

Wireless Systems

RFI- Radio Frequency Interference

- Signals from amateur radios, CBs, and radio and television stations
- Can interfere with data transmissions
- Can Block Radio signals



ASAA – Level 1 Course © ASAA 2023 Slide 10-10

10

Radio Frequency Interference

- Comes from transmitters on a nearby frequency
- Comes from a more powerful source
- Can cause wireless systems to false alarm or “jam” a modules transmission to the panel, causing no alarm or supervisory
- Perform placement tests on each transmitter in a wireless system as per manufacturer’s instructions

ASAA – Level 1 Course © ASAA 2023 Slide 10-11

11

Limited Battery Life

- Typical lifespan for wireless batteries is 1-5 years.
- Will need additional service calls to replace batteries



ASAA – Level 1 Course © ASAA 2023 Slide 10-12

12

Wireless Systems



Arkansas Security Alarm Association
Arkansas Level 1

Section 10-2

Z-Wave or Zigbee

ASAA – Level 1 Course © ASAA 2023Slide 10-13

13

Have you heard of _____ ?

- ADT Pulse or Blue
- Alarm.com
- Total Connect
- SecureCom Wireless
- iBridge



ASAA – Level 1 Course © ASAA 2023Slide 10-14

14

Z-Wave / Zigbee – What is it?

Z-Wave and Zibee (both brand names) are wireless communications protocols used primarily for residential and commercial building automation. It is a mesh network using low-energy radio waves to communicate from device to device, allowing for wireless control of smart home devices, such as smart lights, security systems, thermostats, sensors, smart door locks, and garage door openers.

Both are agnostic, so they are not brand specific. A Z-Wave Schlage lock should work on any Z-Wave network. If you don't like Schlage, a Yale lock will work as well as long as it is Z-Wave compatible.

Z-Wave and Zigbee devices will not work on the other's network. So a Zigbee thermostat will NOT work on a Z-Wave network.

The range is typically limited to about the same as Bluetooth, or about 33'.



ASAA – Level 1 Course © ASAA 2023Slide 10-15

15

Wireless Systems

Devices

There are currently over 1,000 Z-Wave and Zigbee compatible devices, including

- Door locks
- Light switches
- Electrical outlets
- Alarm sensors (burglary, fire, CO, water, etc.)
- Thermostats
- Window shades
- Many more

ASAA – Level 1 Course © ASAA 2023 Slide 10-16

Wiring

 **Arkansas Security Alarm Association**
Arkansas Level 1

Wiring

Chapter 11

ASAA -Level 1 Course © ASAA 2023 Slide 11-1

1

 **Arkansas Security Alarm Association**
Arkansas Level 1

Section 11-1

Cable Preparation and Wiring

ASAA -Level 1 Course © ASAA 2023 Slide 11-2

2

Routing cable and wire

- Keep your wiring neat. NFPA 70, the National Electrical Code required it.

 **D rings**

 **Structured Cabling Enclosure**

NEC 110.12 ASAA -Level 1 Course © ASAA 2023 Slide 11-3

3

Wiring

Backboard Installation

- Pre designed back boards may save time



Backboard for M Blocks

ASAA -Level 1 Course © ASAA 2023 Slide 11-4

4

Rack, Patch Panel & Connection Box

- Consider Patch panels



M Block Mount M or 66 Block 110 Block with legs

ASAA -Level 1 Course © ASAA 2023 Slide 11-5

5

Connection & Mounting Boxes

Mounting Boxes are available to help you mount the device and conceal holes made to route wiring



ASAA -Level 1 Course © ASAA 2023 Slide 11-6

6

Wiring

Service Loops

- Allow enough cable after you make your connections to:
 - Remove the device for service or adjustment
 - Replace it with a similar device
 - Eliminate any strain on the cable and connectors

ASAA - Level 1 Course © ASAA 2023 Slide 11-7

7

Residential Cabling Distribution

- Find areas for splice boxes that will be accessible for service
 - Closets
 - Attics
 - Crawl Spaces
 - Basements
 - Utility rooms

ASAA - Level 1 Course © ASAA 2023 Slide 11-8

8

Commercial Cabling Distribution

- Find areas for splice boxes that will be accessible for service
 - Closets
 - Drop Ceilings
 - Crawl Spaces
 - Basements
 - Utility rooms
 - Phone closets
 - Computer rooms

ASAA - Level 1 Course © ASAA 2023 Slide 11-9

9

Wiring

Home Run vs. Connection Box

- **Home run** wiring saves on splicing isolates each device with its own wire
- **Splice box** wiring allow consolidation of runs and provide intermediate test points

ASAA - Level 1 Course © ASAA 2023 Slide 11-10

10

Splicing

- Splicing is a critical part of the job
- Proper connection of wiring avoids service calls and false alarms
- Use
 - Solder and tape
 - Solder and crimp
 - Crimp with proper connector & tools
 - Terminal or barrier strips or punch blocks

ASAA - Level 1 Course © ASAA 2023 Slide 11-11

11

Supervision

- Connect to allow supervision of devices
- Wire in and out of each device
- No "T" taps

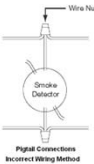

Pigtail Connections
Incorrect Wiring Method

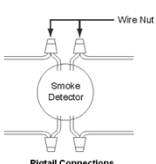

Pigtail Connections
Correct Wiring Method

ASAA - Level 1 Course © ASAA 2023 Slide 11-12

12

Supervision

In the Panel
IS NOT
End of Line

Put the end of line device after the last device

ASAA -Level 1 Course © ASAA 2023 Slide 11-13

13

Match the Connector

- Each type of wiring system has an appropriate connection method and/or connector
- Connectors need to match the wire type and gauge

ASAA -Level 1 Course © ASAA 2023 Slide 11-14

14

Crimp Type

B Connectors

Spade lugs

Crimp Connector

Butt Splice

Quick Disconnect

ASAA -Level 1 Course © ASAA 2023 Slide 11-15

15

Wiring

Twist on or Push type



Wire Nut



Push In Connector

ASAA -Level 1 Course © ASAA 2023 Slide 11-16

16

Terminal Strips



Barrier Strip



Terminal Strip

ASAA -Level 1 Course © ASAA 2023 Slide 11-17

17

RJ45 Connectors

- Follow the specifications for your use
- Use a crimp tool



| PC | STRAIGHT-THRU | HUB | PC | CROSSOVER | PC |
|------|---------------|-----|----|-----------|----|
| TX-1 | 1 | 1B | 1 | TX-1 | 1 |
| TX-2 | 2 | 2B | 2 | TX-2 | 2 |
| RP-3 | 3 | 3B | 3 | RP-3 | 3 |
| RP-4 | 4 | 4B | 4 | RP-4 | 4 |
| RP-5 | 5 | 5B | 5 | RP-5 | 5 |
| RP-6 | 6 | 6B | 6 | RP-6 | 6 |
| RP-7 | 7 | 7B | 7 | RP-7 | 7 |
| RP-8 | 8 | 8B | 8 | RP-8 | 8 |

ASAA -Level 1 Course © ASAA 2023

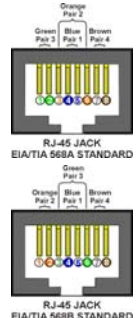

RJ-45 JACK
EIA/TIA 568A STANDARD

RJ-45 JACK
EIA/TIA 568B STANDARD

Color code for network cabling.

ASAA -Level 1 Course © ASAA 2023 Slide 11-18

18

Coaxial Connectors

- Read and follow the manufacturers directions for each type of Coax Connector
- Crimp types require a crimp tool
- Twist on and soldered types require proper cable preparation



ASAA –Level 1 Course © ASAA 2023

Slide 11-19

19

Crimp Connectors

- Use a proper tool to provide even compression on all sides of crimp connectors



ASAA –Level 1 Course © ASAA 2023

Slide 11-20

20

Fiber optic, ST, SC connectors

- Fiber optic termination and connections require special training beyond the time constraint of this course.
- Contact your supplier for appropriate training



ASAA –Level 1 Course © ASAA 2023

Slide 11-21

21

Wiring

Standard 4-Pair UTP Color Codes

| Pair | Tip | Ring |
|------|--------------|--------------|
| 1 | White/Blue | Blue/White |
| 2 | White/Orange | Orange/White |
| 3 | White/Green | Green/White |
| 4 | White/Brown | Brown/White |

An example of a wiring color code for phone lines

ASAA - Level 1 Course © ASAA 2023 Slide 11-22

22



Arkansas Security Alarm Association
Arkansas Level 1

Section 11-2

Wire Buildings

ASAA - Level 1 Course © ASAA 2023 Slide 11-23

23

Secure Area

- Secure each area prior to commencing work
 - Use a drop cloth to avoid damage to carpet or flooring
 - Ensure that extension cords are taped down or are not in traffic paths
 - Use a safety cone to indicate hazards

ASAA - Level 1 Course © ASAA 2023 Slide 11-24

24

Wiring

Kids and Animals

- Keep your tools and parts in a secure area
- Kids and pets may be attracted to them
- Unsupervised access may lead to misplaced items or injury

ASAA -Level 1 Course © ASAA 2023 Slide 11-25

25

Careful With Tools

- Watch where your tool belt swings
- Use care where you place:
 - Soldering guns and irons
 - Hot drill bits
 - Glue guns
 - Sharp tools

ASAA -Level 1 Course © ASAA 2023 Slide 11-26

26

Tools to Fish Wire

Pull Rods 

Fish Tape 

ASAA -Level 1 Course © ASAA 2023 Slide 11-27

27

Wiring

Tools to Fish Wire

Flex Drill Bit 

Stud Sensor 

ASAA -Level 1 Course © ASAA 2023 Slide 11-28

28

Pre-wiring

- In new construction it is to your advantage to run wire through exposed studs and framing before walls are closed in with drywalls or other wall coverings
- Wire should be fastened to prevent damage
- Wire should be protected with kick plates or other protection where nails or screws might hit the wire

ASAA -Level 1 Course © ASAA 2023 Slide 11-29

29

Existing Commercial Buildings

- Most interior walls in commercial buildings are hollow
- Remove a wall plate to verify
- Drop ceilings provide access to walls
- Ceilings should not be used to support the wiring.

ASAA -Level 1 Course © ASAA 2023 Slide 11-30

30

Wiring

Existing Residential Buildings

- Crawl spaces unfinished basements and attics can provide access to walls.
- When wiring can not be fished through walls try:
 - Concealing behind molding or baseboard
 - Concealing under carpet
 - Using surface mounted wire mold to conceal the wiring

ASAA -Level 1 Course © ASAA 2023 Slide 11-31

31

Fishing Wires

- If door or window lines up toward the center of the attic you should be able to drill straight up
- Once the hole is drilled, use the bit, a fish tape or pull rod to fish the wire

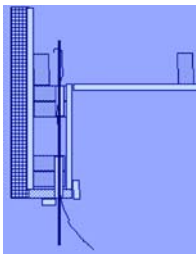

ASAA -Level 1 Course © ASAA 2023 Slide 11-32

32

Fishing Wires to Attic

- If door or window lines up toward the outside of the attic, the pitch of the roof may make it more difficult
- Drill the hole with care to avoid going thru the roof

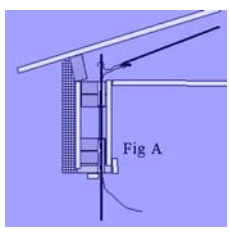

ASAA -Level 1 Course © ASAA 2023 Slide 11-33

33

Wiring

Fishing Wires to Attic

- Extend a fish tape through the hole
- If you are lucky the tape will follow the roof contour to the center of the attic

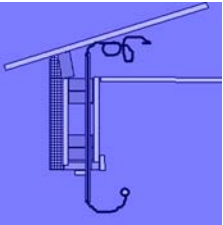

ASAA -Level 1 Course © ASAA 2023 Slide 11-34

34

Fishing Wires to Attic

- If not you will need to use another tape or rod to hook the first tape

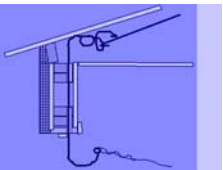

ASAA -Level 1 Course © ASAA 2023 Slide 11-35

35

Fishing Wires to Attic

- To avoid drilling through the roof
- Measure the distance from where you enter the wall or jamb to the ceiling beforehand
- Mark it with tape

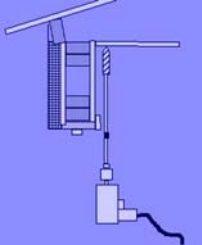

ASAA -Level 1 Course © ASAA 2023 Slide 11-36

36

Wiring

Fishing Wires to Attic

- Drill carefully after the tape mark is reached
- You should feel a hollow space after you make it thru the ceiling and before you enter the roof

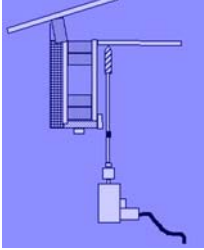

ASAA -Level 1 Course © ASAA 2023 Slide 11-37

37

Fishing Down To The Crawl Space

- Try letting gravity work for you
- Drop a weighted wire or pull line see where it goes

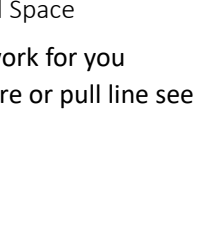

ASAA -Level 1 Course © ASAA 2023 Slide 11-38

38

Fishing Down To The Crawl Space

- You may need to drill up from the basement and down through the floor
- Drop a wire down and try to hook the wire from below with a fish tape



ASAA -Level 1 Course © ASAA 2023 Slide 11-39

39

Wiring

Fastening Wire

- Match the appropriate wire or cable fastener to the situation



Nylon Cable Clips



Cable Tie



Cable tie with Label



Cable Tie With Screw Mount

ASAA -Level 1 Course © ASAA 2023 Slide 11-40

40

Fire Stops



- The horizontal double 2x4s on top of the vertical studs create firestopping in modern wall systems.
- When covered with drywall, each wall cavity will be sealed and separate from the one next to it.

ASAA -Level 1 Course © ASAA 2023 Slide 11-41

41

Fire Stops



- Older homes often have blocks of wood in the walls between the floor and ceiling.
- This stops the vertical movement of fire and hot gases.

ASAA -Level 1 Course © ASAA 2023 Slide 11-42

42

Wiring

Seal All Penetrations

- A fire stop, when properly installed, does exactly what it says. It stops the spread or advancement of fire from one section of a structure to another.
- If you drill a hole you break the fire stop.
- Seal it with an approved sealant



ASAA -Level 1 Course © ASAA 2023 Slide 11-43

43

Conduit



- Metal conduit such as [Electrical Metallic Tubing \(EMT\)](#) or [Galvanized Rigid Conduit \(GRC\)](#) can be bent to the angle you need
- Practice on scrap conduit

ASAA -Level 1 Course © ASAA 2023 Slide 11-44

44

Wiremold

Use to protect surface mounted wiring

For types visit www.wiremold.com

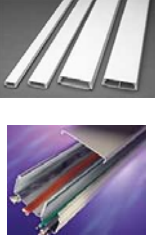

ASAA -Level 1 Course © ASAA 2023 Slide 11-45

45

Wiring

Rough in Device Component Locations

- Pull wire into any mounting or connection boxes whenever possible
- Use bushings to protect cable when pulling through sharp knockouts
- Leave enough slack for the connection and a service loop
- Clearly mark un-terminated cable to avoid damage by other trades



ASAA -Level 1 Course © ASAA 2023 Slide 11-46

46

Label Tag Wire /Cable

- Use wire markers
- Record wiring runs on a floor plan
- Record wiring runs on a wire chart

ASAA -Level 1 Course © ASAA 2023 Slide 11-47

47

Use Wire Markers

- Permanent “Sharpie” magic marker to write on the cable
- Preprinted Numbers or letters
- Custom labeling system



ASAA -Level 1 Course © ASAA 2023 Slide 11-48

48



Arkansas Security Alarm Association
Arkansas Level 1

Section 11-3

Install Components & Other Systems

ASAA - Level 1 Course © ASAA 2023Slide 11-52

52

Assemble Components

- The job will go faster and better if you:
 - Arrange all your components in a convenient location
 - Assemble all components that can be pre-assembled



ASAA - Level 1 Course © ASAA 2023Slide 11-53

53

Mount Components

- Read the instructions for location advice
- Remember to use a fastener to match the surface you are mounting to

ASAA - Level 1 Course © ASAA 2023Slide 11-54

54

Wiring

Mount Components

- Use a level to verify alignment
- Align visible devices with other devices
- Verify that you will have clearance to open or service the device

ASAA – Level 1 Course © ASAA 2023 Slide 11-55

55

Mounting Recessed Door Contacts

- Drill your hole through the top jamb of the door
- Close and latch the door
- Tap firmly on the drywall above the door
- Open the door slowly. The debris that fell out of the wall when you tapped on it should form a perfectly located circle where you need to drill to set your magnet

ASAA – Level 1 Course © ASAA 2023 Slide 11-56

56

Interference

- Check for things that might interfere with the operation of the device before you mount it
- Look on both sides of the wall

ASAA – Level 1 Course © ASAA 2023 Slide 11-57

57

Wiring

Secure Mounting

- Tighten all screws and bolts on mounts and brackets to prevent movement of devices
- Make sure the surface you are mounting to is stable

ASAA – Level 1 Course © ASAA 2023 Slide 11-58

58

Double Stick Tape

- Make sure the surface of the device and the mounting surface are clean
- Make sure the tape will support the weight of the device

ASAA – Level 1 Course © ASAA 2023 Slide 11-59

59

Connect to Control & Distribution Wiring

- Match connectors to wire type
- Check to make sure the connector is rated for the environment and use
- Make sure it can handle the voltage and amperage
- Read the directions
- Crimp connectors as specified

ASAA – Level 1 Course © ASAA 2023 Slide 11-60

60

Wiring

Construction Sites

Protect components from dust, dirt and damage with boxes, plastic bags or packing material if you mount them before construction and cleanup are finished

ASAA - Level 1 Course © ASAA 2023 Slide 11-61

61

Before You Connect Power

- Read the instructions
- Perform indicated tests
- Connect power in the specified sequence

ASAA - Level 1 Course © ASAA 2023 Slide 11-62

62

Be Kind

- To yourself and your coworkers by documenting any devices that are mounted in less visible or hidden locations
- Let your coworkers know how to unlock or remove any special devices that you used to securely mount a device

ASAA - Level 1 Course © ASAA 2023 Slide 11-63

63

Communications



Arkansas Security Alarm Association
Arkansas Level 1

Communications

Chapter 12

ASAA – Level 1 Course © ASAA 2023

Slide 12-1

1

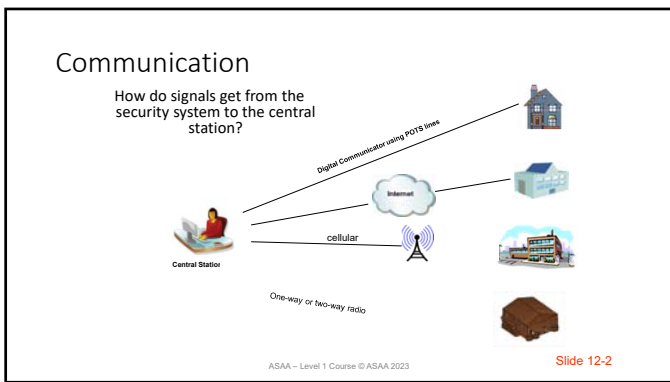

2



Arkansas Security Alarm Association
Arkansas Level 1

Section 12-1

Digital Communicators

ASAA – Level 1 Course © ASAA 2023

Slide 12-3

3

Communications

The RJ31-X

- The connection to the regular phone lines is made through the RJ31-X.
- This provides an FCC approved dividing line between the telephone equipment and our equipment.
- The RJ31-X, when properly wired, allows the alarm equipment to take priority over the phone lines when alarm signals need to be sent.

ASAA – Level 1 Course © ASAA 2023

Slide 12-4

4

RJ31-X Wiring

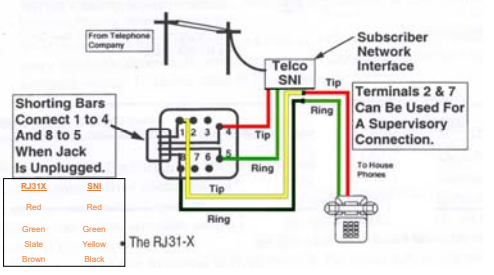

ASAA – Level 1 Course © ASAA 2023

Slide 12-5

5

RJ31-X Wiring (CAT5)

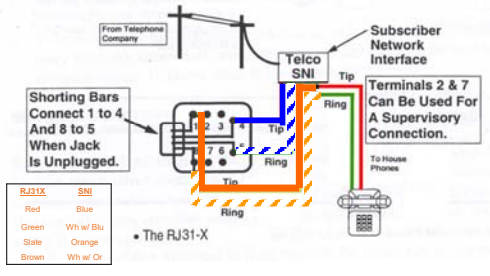

ASAA – Level 1 Course © ASAA 2023

Slide 12-6

6

Communications

Line Seizure

- Notice the little yellow rectangular blocks behind wiring terminals.
- These are the line seizure relays.



- One is connected from T to T1
- The other from R to R1
- When all is well the relays are in the closed position.
- When there is an alarm the relays open disconnecting the house phone

ASAA – Level 1 Course © ASAA 2023

Slide 12-7

7

Color Code For Wiring

Notice wire colors. At top of jack red connects to red and green to green but at the bottom the yellow wire connects to the slate wire and the black wire to the brown wire terminals.

Research done by Moose 15 yrs. ago showed more surge protection by using a longer cord and leaving it wrapped as packed as much as possible.

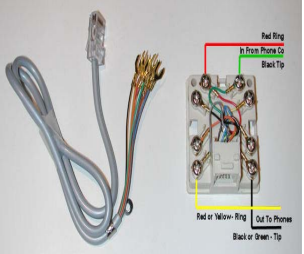

ASAA – Level 1 Course © ASAA 2023

Slide 12-8

8

Subscriber Network Interface



- Point where the phone company responsibility stops and site owners begins

ASAA – Level 1 Course © ASAA 2023

Slide 12-9

9

Communications

Common Residential Telephone Interface (SNI)

ASAA – Level 1 Course © ASAA 2023 Slide 12-10

10

SNI- Points to Remember

- Check voltage make sure no one is talking when you disconnect wiring.
- Make sure there is no connection between Red to Yellow or Green to Black.
- Make sure Yellow and Black terminals are not used as a second phone line.
- Check and record the phone number the RJ31X Jack is on.

ASAA – Level 1 Course © ASAA 2023 Slide 12-11

11

SNI- Points to Remember

- Always use terminals in the interface. Don't connect around the box it has grounding protection.
- Make sure all house phones get reconnected. Old wires break easily.
- With RJ31X jack in place voltage should read 48 to 52 volts DC

ASAA – Level 1 Course © ASAA 2023 Slide 12-12

12

Communications

Every Monitored Account Needs

- Receiver
 - Phone Number / IP Address / Frequency
- Account Number
- Communication Format
- Zone Types
- Signal Types



ASAA – Level 1 Course © ASAA 2023 Slide 12-13

13

Receiver Phone Number / IP Address

- The phone number or IP Address that the control panel needs to reach your central station receiver

* Remember, fire systems have special requirements. See NFPA 72, Chapter 8

ASAA – Level 1 Course © ASAA 2023 Slide 12-14

14

Account Number

- Typically 3 – 6 digit number that identifies home or business
- May have a receiver and line card number, in front of the actual number that you program

01 – 05 – 1234

Receiver Line Card Account Number

ASAA – Level 1 Course © ASAA 2023 Slide 12-15

15

Communications

Duplicate Accounts

- Caution –
- The same line card number and account number may be used on another receiver in the same central station
- Make sure you select the right phone number or IP address

ASAA – Level 1 Course © ASAA 2023 Slide 12-16

16

Communication Format

- The control communicator at the alarm site sends digital data to a receiver at a monitoring center
- The format is like the language (English , French, etc.)
- The format used at the control communicator must match the format used at the receiver

ASAA – Level 1 Course © ASAA 2023 Slide 12-17

17

Common Formats

| | |
|---------------------------|---------|
| • Contact I.D. | • DMP |
| • SIA | • 4 x 2 |
| • Modem IV | • 3 x 1 |
| • Modem IIIa ² | |
| • Modem IIe | |

ASAA – Level 1 Course © ASAA 2023 Slide 12-18

18

Communications

Communication Format

Contact I.D. – Uses DTMF (touch tones)

Includes a four digit account number, one digit event code, three digit event identifier, two digit area, three digit zone/user number.

Example: 

1234 E 134 01 001 and 1234 R 134 01 001

Where:

1234 = Account number E or R = Alarm or Restore
134 = Delay perimeter zone 01 = Area number
001 = Zone number

ASAA – Level 1 Course © ASAA 2023 Slide 12-19

19

Communication Format

SIA – Uses binary frequency shift keying (BFSK).

Format may also include a number (1, 3, 8, 20) that represents how many signals are sent during each phone call.

Examples: 

1234 FA1 1234 BA03 1234 OP006 1

Includes: Four digit account number, Event (FA=Fire Alarm; BA=Burglary Alarm; OP=Opening), Zone/User Number, and may include an area/partition.

ASAA – Level 1 Course © ASAA 2023 Slide 12-20

20

Communication Format

Modem IV, Modem IIIa², Modem IIe – Formats that are proprietary to Bosch (formerly Radionics and Detection System) panels.

Four to ten digit account number, one digit identifier, three digit user/zone number, point text.

Examples: 

1234 A 001 Alarm Zone 1 Back Door
1234 R 001 Restore Zone 1 Back Door
1234 N D25 Test Signal

ASAA – Level 1 Course © ASAA 2023 Slide 12-21

21

Communications

Communication Format

DMP – Uses Synchronous Data Link Control (SDLC), a networking communication format invented by IBM.

Reports up to 47 Characters including keypad displayed information:

Example:
1234 – Area: 01 – Main Bldg Open: User 101 John Doe 

ASAA – Level 1 Course © ASAA 2023 Slide 12-22

22

Communication Format

Pulse – Including 3x1, 3x1 extended, 3x2, 4x2, and 4x3. May include hexi-decimal (replacing numbers with letters). First number is number of digits in account number. Second number represents the number of digits in the event code.

Examples:
123 1 (3x1 format, account # 123, event type 1)
123 01 (3x2 format, account # 123, event type 01)
1234 16 (4x2 format, account # 1234, event/zone 16)
1234 E6 (4x2 format, account # 1234, event E, zone 6) 

ASAA – Level 1 Course © ASAA 2023 Slide 12-23

23



Arkansas Security Alarm Association
Arkansas Level 1

Section 12-2

Cellular Communicators

ASAA – Level 1 Course © ASAA 2023 Slide 12-24

24

Communications

What is Cellular Service?

A terrestrial radio-based service providing two-way communications by dividing the serving area into a regular pattern of sub-areas or cells, each with a base station having a low-power transmitter and receiver. Although cellular radio is primarily a means of providing mobile telephone service, it is also used to provide data services and private voice services, and as an alternative to fixed wired telephone service where this is scarce.

Source: World Trade Organization

ASAA – Level 1 Course © ASAA 2023 Slide 12-25

25

1G, 2G, 3G/4G, LTE, 5Ge, 5G

“G” stands for generation.
“LTE” is long term evolution

ASAA – Level 1 Course © ASAA 2023 Slide 12-26

26

1G or AMPS

- Analog Mobile Phone Service
- Introduced in America in 1973
- First used in alarm systems in about 1992
- Sunset in 2008

ASAA – Level 1 Course © ASAA 2023 Slide 12-27

27

Communications

2G and 2.5G

- Second Generation of cellular service
- Digital communications
- Introduced in 1990
- Life expectancy of 25 years
- Alarm systems typically use GPRS (Global Packet Radio Service) for primary communications with SMS (Short Message Service) for backup.
- Sunset began in 2012, expected to last until 2017.

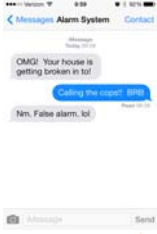

ASAA – Level 1 Course © ASAA 2023 Slide 12-28

28

3G / 4G

- Introduced in 2005
- GSM upgraded High Speed Packet Access (3G) or HSPA+ (4G) for AT&T or T-Mobile users. CDMA was used for Verizon and all other carriers.
- Completely different technology than 1G and 2G networks
- Does NOT support voice or text messaging
- Better for data (smart phones)
- Sunset in 2022



ASAA – Level 1 Course © ASAA 2023 Slide 12-29

29

LTE and LTE-A

- Introduced in 2009
- Operates on a different wireless spectrum than 3G/4G
- Faster data
- No voice or text messaging
- Speeds up to 100MB / second
- Expected life expectancy of 25 years



ASAA – Level 1 Course © ASAA 2023 Slide 12-30

30

Communications

5G

- Introduced in 2018
- Faster data
- Speeds up to 1GB / second
- Each tower supports 10x more devices
- Rollout delayed due to fears of FAA and interference with airline altimeters



ASAA – Level 1 Course © ASAA 2023 Slide 12-31

31



Arkansas Security Alarm Association
Arkansas Level 1

Section 12-3

Network Communicators

ASAA – Level 1 Course © ASAA 2023 Slide 12-32

32

Domain Name System

Since it is easier to remember google.com than it is 74.125.227.65, we use Domain Name Servers to translate IP addresses into useful names.

Like using landmarks and store names rather than latitude and longitude when giving directions.

Alarm systems must use IP addresses, not DNS
Per U.L.

ASAA – Level 1 Course © ASAA 2023 Slide 12-33

33

Communications

Protocols

TCP/IP
Connection

UDP
Connectionless



ASAA – Level 1 Course © ASAA 2023 Slide 12-34

34

Networks

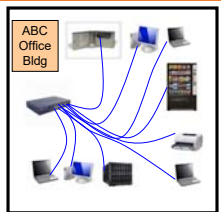

ABC Office Bldg

LANs typically go up to and include the router or firewall.

Example of a local area network (LAN)

ASAA – Level 1 Course © ASAA 2023 Slide 12-35

35

Networks

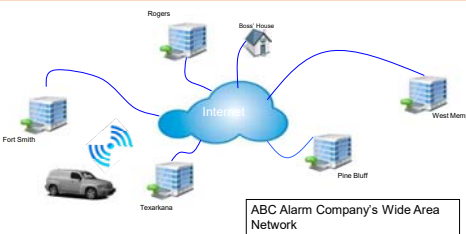

Fort Smith

Rogers

Boss' House

West Memphis

Pine Bluff

Texarkana

ABC Alarm Company's Wide Area Network

ASAA – Level 1 Course © ASAA 2023 Slide 12-36

36

Communications

IPv4

- 32 bit addresses (looks like 192.168.1.1)
- Limited to 4,294,967,296 addresses
- Ran out on February 3, 2011
- Most commonly used by alarm system / receiver manufacturers
- Most will require port forwarding or NATing



ASAA – Level 1 Course © ASAA 2023 Slide 12-37

37

Ports



| Port | Status |
|-----------|--------|
| Port 3060 | No |
| Port 3061 | YES |
| Port 3062 | No |
| Port 3063 | No |
| Port 3064 | No |
| Port 3065 | No |

Every IP address has 65,535 doorways (or Ports) that can be used to access that address.

ASAA – Level 1 Course © ASAA 2023 Slide 12-38

38

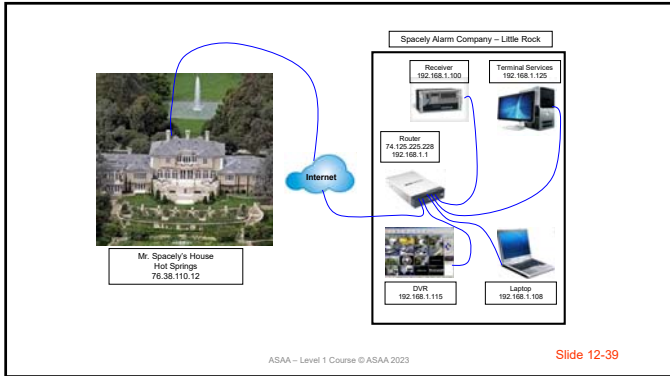

39

Communications

IP Address

Current IP Address
74.125.225.228

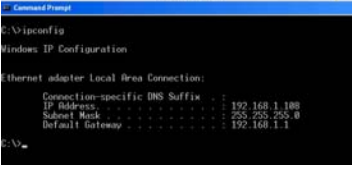

```
Command Prompt
C:\Vipconfig
Windows IP Configuration

Ethernet adapter Local Area Connection:

    Connection-specific DNS Suffix . : 
    IP Address . . . . . : 192.168.1.108
    Subnet Mask . . . . . : 255.255.255.0
    Default Gateway . . . . . : 192.168.1.1

C:\V>
```

ASAA – Level 1 Course © ASAA 2023 Slide 12-40

40

ipconfig

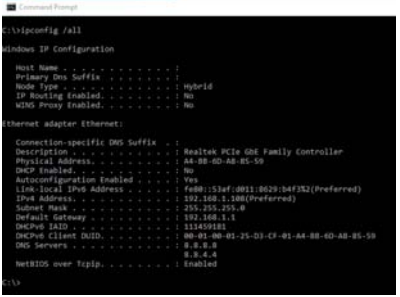

```
Command Prompt
C:\Vipconfig /all
Windows IP Configuration

Host Name . . . . . : 
Primary DNS Suffix . . . . . : 
Node Type . . . . . : Hybrid
IP Routing Enabled. . . . . : No
WINS Proxy Enabled. . . . . : No

Ethernet adapter Ethernet:

    Connection-specific DNS Suffix . : 
    Description . . . . . : Realtek PCIe GbE Family Controller
    Physical Address . . . . . : A4-8D-40-AB-85-58
    DHCP Enabled. . . . . : No
    Autoconfiguration Enabled . . . . : Yes
    Link-local IPv6 address . . . . . : fe80::51af-0011-0629-b4f32(Prefered)
    IPv4 Address. . . . . : 192.168.1.108(Prefered)
    Subnet Mask . . . . . : 255.255.255.0
    Default Gateway . . . . . : 192.168.1.1
    DHCPv6 IAID . . . . . : 111459181
    DHCPv6 Client DUID. . . . . : 00-01-00-00-25-03-C9-01-A4-8D-40-AB-85-58
    DNS Servers . . . . . : 8.8.8.8
    NetBIOS over Tcpip. . . . . : Enabled

C:\V>
```

ASAA – Level 1 Course © ASAA 2023 Slide 12-41

41

tcping

A network tool to check that a port has been opened through a firewall.

Does NOT come with operating system. Will have to be downloaded through a trusted web-site.

May use on IP address or URL

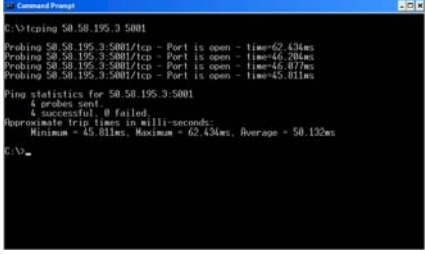

```
Command Prompt
C:\V>tcping 58.58.195.3 5001
Probing 58.58.195.3:5001/tcp - Port is open - time=62.43ms
Probing 58.58.195.3:5001/tcp - Port is open - time=46.204ms
Probing 58.58.195.3:5001/tcp - Port is open - time=46.077ms
Probing 58.58.195.3:5001/tcp - Port is open - time=45.811ms

Ping statistics for 58.58.195.3:5001:
    4 probes sent
    4 successful, 0 failed
    Approximate trip times in milli-seconds:
        Minimum = 45.811ms, Maximum = 62.43ms, Average = 58.132ms

C:\V>
```

ASAA – Level 1 Course © ASAA 2023 Slide 12-42

42

Communications

tracert

- Another DOS (Command Prompt) command that is useful in networking is tracert, trace route.
- tracert will show you the path that an IP packet is taking from your location to any destination, along with the timing.

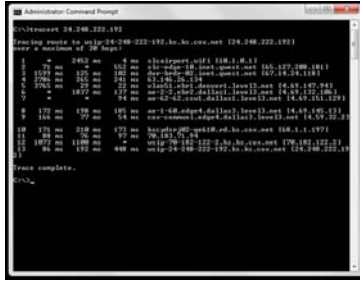

ASAA – Level 1 Course © ASAA 2023

Slide 12-43

43

tracert

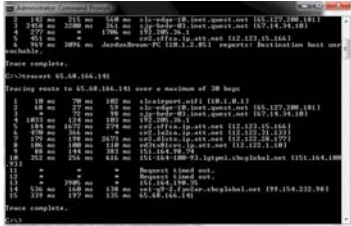

ASAA – Level 1 Course © ASAA 2023

Slide 12-44

44

IPv6

- The world ran out of IPv4 addresses on February 3, 2011.
- IP Version 6 uses 128 bit addressing.
- Creates 3.4×10^{38} addresses.
- IPv6 addresses are represented as eight groups of four hexadecimal digits separated by colons, for example
2014:0bd8:85a3:1041:8080:8a2a:0370:7443

ASAA – Level 1 Course © ASAA 2023

Slide 12-45

45

Communications

IPv6

- Most ISPs support both IPv4 and IPv6
- Security products manufacturers typically still only support IPv4
- IPv4 and IPv6 should both be supported for many years

ASAA – Level 1 Course © ASAA 2023 Slide 12-46

46



Arkansas Security Alarm Association
Central Station Course

Radio

Chapter 12-4

ASAA – Level 1 Course © ASAA 2023 Slide 12-47

47

Radio Communicators

- Unlike digital communicators, internet communicators, and cellular communicators, radio communicators do NOT involve a third party (phone or company) for service. Radio systems are generally maintained by the alarm company.



ASAA – Level 1 Course © ASAA 2023 Slide 12-48

48

Communications

Radio Frequency

- The Federal Communication Commission (FCC) has set aside radio frequencies for use in alarm communications.
- Frequency allocation may be viewed at: www.fcc.gov/oet/spectrum/table/fcctable.pdf



ASAA – Level 1 Course © ASAA 2023 Slide 12-49

49

Radio Frequency

- The Federal Communication Commission (FCC) limits the power of the radio communicators to two watts.
- Limiting the power of the transmitter also limits the range of the radio signal.
- Exceptions may be made.



ASAA – Level 1 Course © ASAA 2023 Slide 12-50

50

One-way Radio Communicators

- Digital Alarm Radio Transmitters (DART) communicate without receiving any acknowledgement from the Digital Alarm Radio Receiver (DARR).
- Multiple transmissions are communicated in attempt to ensure that at least one transmission is received.

ASAA – Level 1 Course © ASAA 2023 Slide 12-51

51

Communications

Repeaters

The diagram shows a green mountain labeled "Mount Rightintheway" with a tower on top. To the left is a building labeled "Central Station" and to the right is a house labeled "Joe Customer".

ASAA – Level 1 Course © ASAA 2023 Slide 12-52

52

Two-way Radio Communicators

- Digital Alarm Radio Transmitters (DART) communicate and receive an acknowledgement from the Digital Alarm Radio Receiver (DARR).
- If the signal is not received, the transmitter re-transmits the signal again.

ASAA – Level 1 Course © ASAA 2023 Slide 12-53

53

Two-way communicator

The diagram shows a green mountain labeled "Mount Rightintheway" with a tower on top. To the left is a building labeled "Central Station" and to the right is a house labeled "Joe Customer".

ASAA – Level 1 Course © ASAA 2023 Slide 12-54

54

Communications

Transceiver

- A device capable of sending and receiving signals.

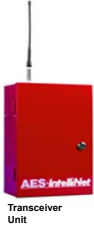

ASAA – Level 1 Course © ASAA 2023 Slide 12-55

55

Two-way Radio Network

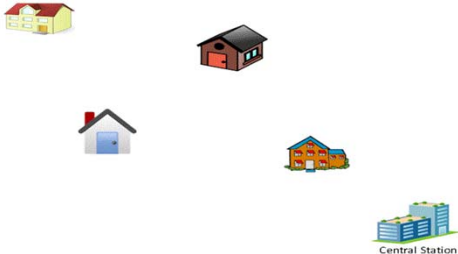

ASAA – Level 1 Course © ASAA 2023 Slide 12-56

56

Radio Advantages

- Great for clients with no "home phone."
- Difficult to defeat
- Expanding radio network coverage
- Reliable
- Cost effective
- No third party service provider
- Fire communicator without backup

ASAA – Level 1 Course © ASAA 2023 Slide 12-57

57

Radio Disadvantages

- No third party service provider
- Limited range
- Inability to up/download panels

ASAA – Level 1 Course © ASAA 2023 Slide 12-58

58

Configure-Program



Arkansas Security Alarm Association

Arkansas Level 1

Configure & Program

Chapter 13

ASAA – Level 1 Course © ASAA 2023Slide 13-1

1

Calibrate & Align

- Many devices will require electronic or physical calibration
 - Motion sensors
 - Glassbreak sensors
 - Contacts
 - Wireless Transmitters

Read the Directions!

ASAA – Level 1 Course © ASAA 2023Slide 13-2

2

Calibrate & Align

- Verify that the device works as it should
- Walk test
- Use recommended test equipment
- Make sure device is securely mounted

Read the Directions!

ASAA – Level 1 Course © ASAA 2023Slide 13-3

3

Configure-Program

Labeling Devices

- Use names and labels that the customer, the police or fire authorities & your fellow workers will understand
- Will everyone know
 - where Billy's room is?
 - north, south, east or west?
 - Right or left, from inside or out?

ASAA – Level 1 Course © ASAA 2023 Slide 13-4

4

Programming Methods

- Via control or keypad
- Via special programmer
- Via notebook or handheld computer
- Via a modem
- Via the internet

ASAA – Level 1 Course © ASAA 2023 Slide 13-5

5

Avoid False Alarms

- Notify your monitoring center **BEFORE** you change a program
- Program changes may send accidental signals

ASAA – Level 1 Course © ASAA 2023 Slide 13-6

6

Configure-Program

Notify Occupants

Let all occupants know when your program changes might result in trouble buzzers or alarm sounds

ASAA – Level 1 Course © ASAA 2023 Slide 13-7

7

Check Integration

The changes you make on one control device may impact another

- Doors may lock, unlock or close
- Elevators may be recalled
- HVAC may be effected

Read the Directions!

ASAA – Level 1 Course © ASAA 2023 Slide 13-8

8

Learn the Options

- Familiarize yourself with the options for each step of the program
- Make sure that a change in one step of your program will not impact another area of the program

Read the Directions!

ASAA – Level 1 Course © ASAA 2023 Slide 13-9

9

Configure-Program

Install or enter control programs

- Gather needed information
 - Device locations & descriptions
 - Identification or account number assigned to the system
 - Special requirements- 24 hour zones, long entry and exit paths, etc.
- Decide on options

ASAA – Level 1 Course © ASAA 2023 Slide 13-10

10

Save Before Updating

- When you update an existing program make sure you have a copy of the most up to date program BEFORE you make changes
- Remember that if you upload or download a program it will probably replace the existing copy of the program

ASAA – Level 1 Course © ASAA 2023 Slide 13-11

11

Install or enter control programs

- Record needed information
 - Use templates or programming sheets.
- Enter the program
- Save the program
- Make notes to help those who come after you

ASAA – Level 1 Course © ASAA 2023 Slide 13-12

12

Configure-Program

Create Program Library

You can save time and avoid mistakes by creating program libraries for common situations

- Small Home
- Larger Home
- Commercial
- Etc.

ASAA – Level 1 Course © ASAA 2023 Slide 13-13

13

Zone Types

- How each zone will react to open, short, and normal conditions in the armed (away, stay) and disarmed modes.

ASAA – Level 1 Course © ASAA 2023 Slide 13-14

14

Zone Types

- **24 Hour**
 - On regardless of arm/disarm status
 - Initiates alarm immediately when tripped
- **Examples**
 - Hold-up
 - Ambush
 - Emergency
 - Fire

ASAA – Level 1 Course © ASAA 2023 Slide 13-15

15

Configure-Program

Zone Types

- **Delay or Entry/Exit**
 - When violated, allows time to reach keypad for disarming
- **Instant**
 - If violated while system is armed, initiates an alarm immediately
- **Follower**
 - Instant if violated first, follows delay if entry/exit zone trips first

ASAA – Level 1 Course © ASAA 2023 Slide 13-16

16

Zone Types

- **Smoke detector verification**
 - Upon activation, control will power down/restore power to device.
 - If zone trips again within time frame, fire alarm is initiated.
 - If zone does not trip within time frame, first trip is ignored.

(For Smoke Detectors ONLY!)

ASAA – Level 1 Course © ASAA 2023 Slide 13-17

17

Zone Types

- **Day Zone**
 - Trouble when disarmed, alarm when armed. (e.g. window foil, tampers)
- **Chime**
 - Sounds at keypads only

ASAA – Level 1 Course © ASAA 2023 Slide 13-18

18

Configure-Program

Signal Types

- How each zone will report to the monitoring station under given conditions (opens, shorts, normal).
 - **Alarm** - Event that requires action (dispatch)
 - **Supervisory** - System is off normal
 - **Trouble** - System will not work as designed
 - **Restore** - System or zone is back to normal condition
 - **Cancel** - Previous alarm signal, or alarm in process, is to be disregarded.

ASAA – Level 1 Course © ASAA 2023 Slide 13-19

19

Test and Verify

Verify proper system operation after each major program change

ASAA – Level 1 Course © ASAA 2023 Slide 13-20

20

Restore the System

Notify your monitoring center **after** you have finished all testing to restore the system to normal operation.

ASAA – Level 1 Course © ASAA 2023 Slide 13-21

21

Configure-Program

Record All Changes

Make sure that all documentation is updated when you make a change

ASAA – Level 1 Course © ASAA 2023 Slide 13-22

22

Control Panel Features

- Several Control Panel features can help to reduce false alarms if used correctly
- SIA – CP01 Standard establishes guidelines to be followed



ASAA – Level 1 Course © ASAA 2023 Slide 13-23

23

Abort Window

- A period of time that allows the user additional time to disarm the system before an alarm is transmitted.
- Too little time prevents the user from disarming the system after false alarms.
- All panels should be set to at least the default of 30 seconds established by the SIA CP-01 Standard.
- Time should be extended depending on environment or user.

ASAA – Level 1 Course © ASAA 2023 Slide 13-24

24

Configure-Program

Swinger Shutdown

- One trip will shut down a zone until it is restored by a manual reset or may be automatically reset after forty-eight hours with no additional trips on any zones.
- If swinger shutdown is set above 1, faulty equipment or environment will continue to cause a false alarm from the same source.
- All panels should be set to the default of 1 established by the SIA CP-01 Standard.

ASAA – Level 1 Course © ASAA 2023 Slide 13-25

25

Exit Delay

- Time allowed for user to arm (activate) the system and exit.
- Sufficient delay time will help reduce false alarms from the source.
- All panels should be set to the default of 60 seconds established by the SIA CP-01 Standard.
- A test should be performed to ensure all users can easily walk the distance in the time allowed.

ASAA – Level 1 Course © ASAA 2023 Slide 13-26

26

Exit Time Restart

- If the alarm user reenters premise prior to the end of the exit delay time, the exit time shall restart.
- Panels without this feature enabled will go into alarm if a person reenters at the end of the exit period.
- All panels should use this feature to allow the user time to reenter and reduce exit alarms.

ASAA – Level 1 Course © ASAA 2023 Slide 13-27

27

Configure-Program

Device Identification

- Various methods can be used to pinpoint the source of an alarm.
- If too many devices activate the same signal, it can be difficult to locate the source on an alarm.
- The number of devices wired to each zone should be limited to more accurately identify the source of a false alarm.

ASAA – Level 1 Course © ASAA 2023 Slide 13-28

28

Entry Delay

- Period of time allowed, after entry to the premises, to disarm (deactivate) the security system before it notifies the monitoring company.
- If the user does not have enough time to disarm (deactivate) the security system, false alarms are likely.
- All panels should be set for at least 60 seconds (SIA default is 30 seconds)
- A test should be performed to ensure all users can easily walk the distance in the time allowed.

ASAA – Level 1 Course © ASAA 2023 Slide 13-29

29

Test, Troubleshoot, Debug



Arkansas Security Alarm Association

Arkansas Level 1

Test Troubleshoot & Debug

Chapter 14

ASAA – Level 1 Course © ASAA 2023Slide 14-1

1

Testing & Troubleshooting Aids

| | |
|---|--|
| <ul style="list-style-type: none">• Instruction Manuals• Test equipment• Work Order• Contract• Blueprints• Manufacturer help lines• Web sites | <ul style="list-style-type: none">• Your sense of<ul style="list-style-type: none">• Smell• Hearing• Sight• Touch• Taste |
|---|--|

ASAA – Level 1 Course © ASAA 2023Slide 14-2

2

Read the Paperwork

- Instruction Manuals
 - Guide you on sequence of power up
 - Tell you how it should work and perform
- Work order
 - Lets you know what the customer expects
- Blue prints
 - Tells you where things should be
- Wire Chart
 - Identifies what is connected to what

ASAA – Level 1 Course © ASAA 2023Slide 14-3

3

Test, Troubleshoot, Debug

Measure Voltage

- Verify meter setting and lead placement
 - On Voltage
 - On AC or DC
 - On range that you do not expect to exceed
- Place leads in **PARALLEL** with what you are measuring
- Disconnect a battery from the panel to measure the battery voltage or the charging circuit

ASAA – Level 1 Course © ASAA 2023 Slide 14-4

4

Measure Amperage

- Verify meter setting and lead placement
 - On Amperage
 - On range that you do not expect to exceed
- Place leads in **SERIES** with what you are measuring

ASAA – Level 1 Course © ASAA 2023 Slide 14-5

5

Measure Resistance

- Verify meter setting and lead placement
 - On Resistance
 - On range that you do not expect to exceed
- Disconnect from battery and panel
- Place leads in **PARALLEL** with what you are measuring

ASAA – Level 1 Course © ASAA 2023 Slide 14-6

6

Test, Troubleshoot, Debug

Check Telephone Lines

- Use a Lineman's test set to:
 - Verify dial tone
 - Test ability to dial out
 - Check requirements to dial (Dial 9)
- Use a Meter to:
 - Verify if line is active
 - 48 to 52 volts DC on Hook
 - 7 to 9 volts DC Off Hook



ASAA – Level 1 Course © ASAA 2023 Slide 14-7

7

Testing New Systems

- Read the instruction manuals
- Perform tests indicated in the manuals
- Check that wiring and connections are complete
- Connect power in the sequence specified in the instructions
- Verify proper operation

ASAA – Level 1 Course © ASAA 2023 Slide 14-8

8

Troubleshooting

- Find the problem
- Identify a solution
- Implement the solution
- Verify proper operation
- Make sure that was the only problem
- Document problems and actions taken

ASAA – Level 1 Course © ASAA 2023 Slide 14-9

9

Test, Troubleshoot, Debug

Find the Problem

- Discuss the problem with the customer
- Compare the problem to past problems you have experienced
 - Look for common sources of problems

ASAA – Level 1 Course © ASAA 2023 Slide 14-10

10

Find the Problem

- Compare the current operation to desired operation
 - Ask your central station
 - Observe the situation
 - Test operation
 - Check voltage and resistance

ASAA – Level 1 Course © ASAA 2023 Slide 14-11

11

Find the Problem

- Use process of elimination
 - Substitute good parts for suspected bad parts
 - Bridge or jump out sections of a circuit
- Cool or heat a component to restore to normal operation or reveal abnormal operation
- Note changes

ASAA – Level 1 Course © ASAA 2023 Slide 14-12

12

Test, Troubleshoot, Debug

Ask...

- What zone(s)?
- Is it time related?
- Is it event related?
- Is it user related?
- Is it environment / weather related?

ASAA – Level 1 Course © ASAA 2023 Slide 14-13

13

Ask...

- Have any other contractors been working in the area?
- Any recent remodels, roof leaks, etc.?
- Keep a log to show trends and patterns

ASAA – Level 1 Course © ASAA 2023 Slide 14-14

14

Detailed & Accurate Diagnosis

- This is an absolute must!
- “It’s broke” or “It doesn’t work” doesn’t tell you anything
- Ask; who, what, when, where & why?

ASAA – Level 1 Course © ASAA 2023 Slide 14-15

15

Test, Troubleshoot, Debug

Swingers

Problems that are erratic or intermittent - that come and go suddenly - are almost always due to bad connections - cold solder joints or internal or external connectors that need to be cleaned and reseated

ASAA – Level 1 Course © ASAA 2023 Slide 14-16

16

No Functions

- Problems that result in a totally dead unit or affect multiple functions are generally power supply related

ASAA – Level 1 Course © ASAA 2023 Slide 14-17

17

Test Operation

- Read the Directions
- Walk test
- Sequence through the operation as the user would
- Check voltage, resistance, tones
- While checking resistance move wiring or vibrate components to verify firm connections

ASAA – Level 1 Course © ASAA 2023 Slide 14-18

18

Test, Troubleshoot, Debug

Sources of Problems

- People
- Animals, insects and rodents
- Environment- heat, moisture, airflow
- Dust, dirt and contaminants
- Remodeling or movement of items
- Improper installation or application

ASAA – Level 1 Course © ASAA 2023 Slide 14-19

19

Sources of Problems

- Grounds, Noise -EMI, RFI, humbars, audio noise, feedback, etc.
- Wear and tear
- Shorts and Opens
- Abnormal or excessive movement of parts
- Defective equipment- mechanical faults

ASAA – Level 1 Course © ASAA 2023 Slide 14-20

20

Signs of Short Circuits

- Blown fuses, breakers or transformers
- Increased heat
- Low voltage
- High amperage
- Smoke or smell of smoke

ASAA – Level 1 Course © ASAA 2023 Slide 14-21

21

Test, Troubleshoot, Debug

Signs of Open Circuits

- Infinite resistance
- Zero Amperage
- Inoperable device

ASAA – Level 1 Course © ASAA 2023 Slide 14-22

22

Signs of Grounds

- Abnormal voltage readings
- Abnormal amperage readings
- Abnormal resistance readings
- Shocks
- Abnormal circuit performance
- Tripped ground fault interrupters
- Blown fuses or breakers

ASAA – Level 1 Course © ASAA 2023 Slide 14-23

23

Signs of Mechanical Faults

- Noisy operation
- Abnormal operation
- Visual clues
 - Cracks, burns, charred areas
- Smells
- Heat
- Circuit failure

ASAA – Level 1 Course © ASAA 2023 Slide 14-24

24

Test, Troubleshoot, Debug

Programming

- Keep in mind all of the effects that programming can create in the system
- You must know your equipment - including ALL program options

ASAA – Level 1 Course © ASAA 2023 Slide 14-25

25

Connections

- Anything that has human intervention, either during the installation, day-to-day use or maintenance will be the MOST likely place to find problems

ASAA – Level 1 Course © ASAA 2023 Slide 14-26

26

Overloading

- A very common mistake made during the original design and installation
- Too many devices drawing too much current from the panel's power supply

ASAA – Level 1 Course © ASAA 2023 Slide 14-27

27

Test, Troubleshoot, Debug

Undersize Wiring

- Mostly a factor on;
 - Long runs (>200')
 - Data or Polling loops
 - High current devices (i.e. sirens & horns)

ASAA – Level 1 Course © ASAA 2023 Slide 14-28

28

Undersize Wiring

- Most manufacturers recommend a minimum of 22AWG wire for zones and 18AWG (minimum) for the transformer and siren
- Read the manufacturers instructions!

ASAA – Level 1 Course © ASAA 2023 Slide 14-29

29

Excessive Wire Length

- Verify wire runs over 200' with the installation instructions.
- If there is no chart in the manual - call the manufacturer
- Keep in mind, the electrons have to travel 200' out AND 200' back to the panel

ASAA – Level 1 Course © ASAA 2023 Slide 14-30

30

Test, Troubleshoot, Debug

Improper Installation Not installed as per Manufacturers Instructions

- Keep in mind that if you service this system without correcting the misapplication - NOW YOU ARE LIABLE

ASAA – Level 1 Course © ASAA 2023 Slide 14-31

31

Improper Application

- Violates U.L. listings
- Violates NFPA
- IS AGAINST THE LAW!

ASAA – Level 1 Course © ASAA 2023 Slide 14-32

32

Electro-Magnetic Interference

- From Lightning - can travel great distances over power lines, telephone lines or any conductor. It can even be picked up by the zone wiring. (Use twisted wire to reduce this effect.)
- From light ballast's or utility power transformers

ASAA – Level 1 Course © ASAA 2023 Slide 14-33

33

Test, Troubleshoot, Debug

Radio Frequency Interference

- From nearby radio towers, cellular sites, broadcast antenna's, etc..
- This is a rare problem, but not unheard of
- Typically interfering transmissions should be within the same frequency range to cause problems

ASAA – Level 1 Course © ASAA 2023 Slide 14-34

34

Lack of Cellular Service

- Antennas and/or amplifiers may be required in rural areas with little or no cellular coverage.



ASAA – Level 1 Course © ASAA 2023 Slide 14-35

35

VoIP

- Voice Over Internet Protocol
- Can work one minute and not the next
- Verify with VoIP provider
- Verify with manufacturer of alarm panel
- Warn customers to check with you before they switch

ASAA – Level 1 Course © ASAA 2023 Slide 14-36

36

Test, Troubleshoot, Debug

Identify a Solution

- Remember what worked before
- Ask Coworkers, Supervisors
- Read the manuals
- Use manufacturer help lines, web sites
- Break down the problem into smaller parts

ASAA – Level 1 Course © ASAA 2023 Slide 14-37

37

Keep in Mind...

- Components seldom “just go bad”. Something caused it
- Connections inside J-boxes and attics seldom go bad (depending on geographic location)
- Wire seldom goes bad...without a cause

ASAA – Level 1 Course © ASAA 2023 Slide 14-38

38

Blocked Ventilation

- Make sure vents remain unblocked
- Check that cooling fans operate

ASAA – Level 1 Course © ASAA 2023 Slide 14-39

39

Test, Troubleshoot, Debug

Use Process of Elimination

- Mentally eliminate everything it couldn't be
- Don't waste time with these parts of the system unless your updated diagnosis indicates reconsideration

ASAA – Level 1 Course © ASAA 2023 Slide 14-40

40

Use Common Sense

- “Nothing works”; check: power supply, fuse, transformer or circuit breaker?
- If the key pad or other components are working...its not auxiliary power

ASAA – Level 1 Course © ASAA 2023 Slide 14-41

41

Implement the Solution

- Make sure your solution will address the problem
 - Use common sense
 - Use your experience
 - Ask coworkers and supervisors
 - Refer to manufacturer manuals, websites and help lines
 - Observe

ASAA – Level 1 Course © ASAA 2023 Slide 14-42

42

Test, Troubleshoot, Debug

Verify proper operation

- Test after each fix to make sure it is really fixed
- Make sure that your fix did not break something else

ASAA – Level 1 Course © ASAA 2023 Slide 14-43

43

Make Sure That Was The Only Problem

- You may fix what you think is the problem and leave another problem uncorrected
- Test the full system before you leave

ASAA – Level 1 Course © ASAA 2023 Slide 14-44

44

Document Problems & Actions Taken

- Record the steps you took to fix or change the system
- This avoids repeating the same steps if the problem happens again

ASAA – Level 1 Course © ASAA 2023 Slide 14-45

45

Test, Troubleshoot, Debug

Poor Troubleshooting Techniques

- “Shotgun” approach - change out components until the problem goes away
- “Curing the symptom” - not correcting what caused the problem in the first place
- Failure to replace outdated components or technology known to cause problems
- Failure to maintain system on a regular basis (i.e. battery)

ASAA – Level 1 Course © ASAA 2023 Slide 14-46

46

Problems With The “Shotgun Approach”

- Wastes precious billing time on unnecessary components
- Costs either you or the customer more in labor billings/charges
- Often it only fixes the symptom
- Doesn't look professional to the customer

ASAA – Level 1 Course © ASAA 2023 Slide 14-47

47

S.W.A.G.

- “Silly, wild ‘aggie’ guess”.
- Makes you as an installer/technician seem incompetent
- Reflects poorly on your company and the industry

ASAA – Level 1 Course © ASAA 2023 Slide 14-48

48

Test, Troubleshoot, Debug



Class Exercise



What was your most recent
service call?
How did you fix it?

ASAA – Level 1 Course © ASAA 2023

Slide 14-49

49

Train Users



Arkansas Security Alarm Association
Arkansas Level 1

Train Users

Chapter 15

ASAA -Level 1 Course © ASAA 2023Slide 15-1

1

Review User Documentation (Manuals & Instructions)

- To properly demonstrate the operation of a system you need to be an expert in how it operates
 - Read the instruction manual
 - Run through the system until you are comfortable



ASAA -Level 1 Course © ASAA 2023Slide 15-2

2

Identify Training Objectives

- Decide which features to cover
- Proper training is a critical part of good customer service
- Get it right -return visits are costly
- Confirm who all the actual users are

ASAA -Level 1 Course © ASAA 2023Slide 15-3

3

Train Users

Procure – Develop Training & User Aids

- Write a script based on user documentation to train a customer
- Have manuals and videos on hand



ASAA –Level 1 Course © ASAA 2023 Slide 15-4

4

Demonstrate System Functions And Capabilities

- Repeat a pre-developed script to train a customer
- Demonstrate a system
- Compare common ways to train customers e.g. demonstration, video, written manual



ASAA –Level 1 Course © ASAA 2023 Slide 15-5

5

Guide User Through System

- Sequence the customer through the operation of the system
- Use clear & understandable descriptions
- **Let the user show you each step**
- Involve the customer in the demonstration



ASAA –Level 1 Course © ASAA 2023 Slide 15-6

6

Train Users

False Alarm Prevention

- Explain the impact of false alarms
 - Cost to police
 - Danger to responders
 - Cost of alarm fines
- Stress that anyone with a key be trained

ASAA -Level 1 Course © ASAA 2023 Slide 15-7

7

False Alarm Prevention

- Explain how to cancel an alarm
- Describe the difference between the keypad code and the cancel code

ASAA -Level 1 Course © ASAA 2023 Slide 15-8

8

Verify and Document

- Ask questions
- Document any problems experienced by the customer during training
- Document when each customer is trained



ASAA -Level 1 Course © ASAA 2023 Slide 15-9

9

Train Users

Use a Video

- Available online at
 - faraonline.org
 - nesaus.org



Create your own video with your co-workers.

ASAA – Level 1 Course © ASAA 2023 Slide 15-10

10

Continue the Training

- Add bulletins in invoices or newsletters
- Offer training to new employees or users
- Give refresher training after false alarms
- Make additional manuals available if customer loses theirs.



- Use free resources available at www.faraonline.org

ASAA – Level 1 Course © ASAA 2023 Slide 15-11

11

As Built Documentation



Arkansas Security Alarm Association
Arkansas Level 1

As Built Documentation

Chapter 16

ASAA – Level 1 Course © ASAA 2023Slide 16-1

1

Reasons for Documentation

- Helps to determine actual job costs
- Helps on future service calls
- Helps to explain system to customer without a visit to the site
- Helps if there is ever a question about what was installed

ASAA – Level 1 Course © ASAA 2023Slide 16-2

2

User Manual & Training Materials

- Simplify the manual for the customer
- Note any changes from normal operation
- Note any special features



ASAA – Level 1 Course © ASAA 2023Slide 16-3

3

As Built Documentation

“As Built” Drawings

- Mark a set of floor plans or blueprints to:
 - Show the final system as installed
 - Show route of wiring
 - Location of devices
- Make a set for the site and another for the files

ASAA – Level 1 Course © ASAA 2023 Slide 16-4

4

Zone Diagram

- Do a diagram of what is connected to each zone
- Show the type and location of connected devices
- Make a set for the site and another for the files

ASAA – Level 1 Course © ASAA 2023 Slide 16-5

5

Equipment Lists

- List the type and model of installed equipment
- Make a set for the site and another for the files

ASAA – Level 1 Course © ASAA 2023 Slide 16-6

6

As Built Documentation

Commercial Fire Systems

NFPA 72 requires 17 documents be submitted for review and approval for new systems, additions, and alterations. They are:

| | |
|--|---|
| (1)* Written narrative providing intent and system description | (9) Mounting height elevation for wall-mounted devices and appliances |
| (2) Riser diagram | (10) Minimum sound pressure levels |
| (3) Floor plan layout showing locations of all devices, control equipment, and supervising station and shared communications equipment with each sheet | (11) Locations of alarm notification appliances, including candela ratings for visual alarm notification appliances |
| (4) Sequence of operation in either an input/output matrix or narrative form | (12)* Pathway diagrams between the control unit and shared communications equipment within the protected premises |
| (5) Equipment technical data sheets | (13) Completed record of completion |
| (6) Manufacturers' published instructions, including operation and maintenance instructions | (14) For software-based systems, a copy of site-specific software |
| (7) Battery capacity and safety margin calculations | (15) Record (as-built) drawings |
| (8) Voltage drop calculations for notification appliance circuits | (16) Records, record retention, and record maintenance |
| | (17) Completed record of inspection and testing |

ASAA – Level 1 Course © ASAA 2023 Slide 16-7

7



Class Exercise



Tell us an example of how as built documentation helped you to install add-on equipment or do a service call

ASAA – Level 1 Course © ASAA 2023 Slide 16-8

8

Warranty Paperwork

- The warranty is clarified and enforceable with proper documentation that states:
 - What is covered
 - When the coverage begins and ends
 - Demonstrates that the customer accepted the system

ASAA – Level 1 Course © ASAA 2023 Slide 16-9

9



As Built Documentation

Change Orders

Written documentation should be signed by the customer to identify any changes from the contract, even if the changes are at no additional charge

ASAA – Level 1 Course © ASAA 2023 Slide 16-10

10

 Class Exercise 

Tell us some common reasons for change orders

ASAA – Level 1 Course © ASAA 2023 Slide 16-11

11

Maintenance & Repair



Arkansas Security Alarm Association
Arkansas Level 1

Maintenance & Repair

Chapter 17

ASAA – Level 1 Course © ASAA 2023Slide 17-1

1

Maintenance

A “Check-up”
Recurrent inspections,
tests and corrections to
keep the system and it’s
component parts in an
operative condition at
all times



ASAA – Level 1 Course © ASAA 2023Slide 17-2

2

Benefits of Maintenance

- Verify proper operation
- Reduce chance of system failure
- Extend the life of system components

ASAA – Level 1 Course © ASAA 2023Slide 17-3

3

Maintenance & Repair

Timing of Maintenance

- Standards
- Manufacturer's guidelines
- Warranty
- Customer Requirements



ASAA – Level 1 Course © ASAA 2023 Slide 17-4

4

Common Maintenance Tasks

- Cleaning
- Alignment
- Voltage and resistance tests
- Operation testing
- Check environment for changes that could effect operation
- Replacement of worn out parts



ASAA – Level 1 Course © ASAA 2023 Slide 17-5

5

Repair

- To restore by replacing a part or putting together what is torn or broken
- To fix
- To restore to a sound or healthy state



ASAA – Level 1 Course © ASAA 2023 Slide 17-6

6

Maintenance & Repair

Diagnose Source Of Problem

- Remember the troubleshooting steps
 - Listen
 - Observe
 - Correct
 - Verify



ASAA – Level 1 Course © ASAA 2023 Slide 17-7

7



Class Exercise



Tell us about a recent maintenance call and what the condition of the system was

ASAA – Level 1 Course © ASAA 2023 Slide 17-8

8



Level I Homework

Convert the following:

250 mA (milli-Amps) = _____ Amps

4.7K Ω (killo-Ohms) = _____ Ω

50 μ A (micro-Amps) = _____ Amps

3,300 Ω = _____ K Ω (killo-Ohms)

$E_T = 12V$

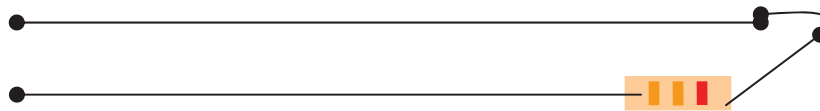

$R_T = 3.3K\Omega$

What is the current of the circuit above? _____ A or _____ mA

What is the size (Ohms and tolerance) of a resistor with the following color bands?

Band 1 = Grey

Band 2 = Orange

Band 3 = Red

Band 4 = Silver

_____ $\Omega \pm$ _____ %

What fire (building) code has Arkansas adopted? _____

What state agency regulates alarm companies in Arkansas? _____

What type of door contact is more difficult to defeat due to a magnet built into the switch? _____

What is the minimum standby battery time that should be provided? _____ hours

What regulating agencies ensures safety on a job-site? _____

